

**DUCATI** energia  
HISTORY DRIVES THE FUTURE

## POWER ELECTRONIC CAPACITORS

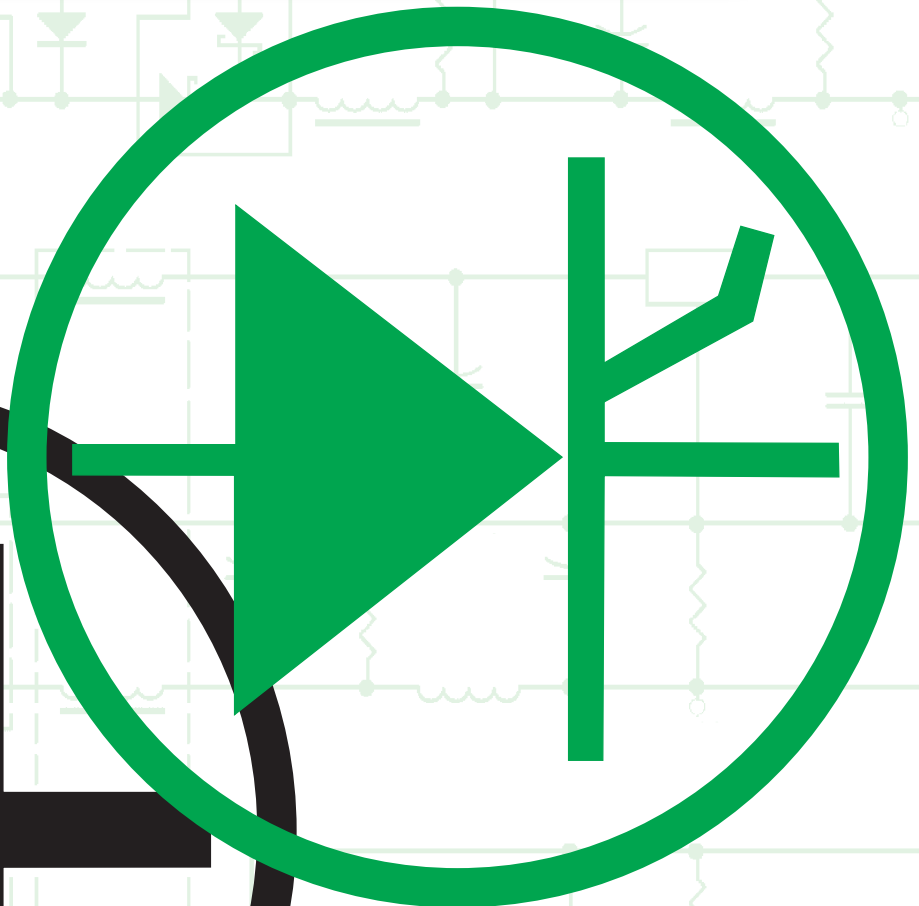

ESTABLISHED IN 1926





# POWER ELECTRONICS CAPACITORS

## MAIN TYPES OF CAPACITORS:

CAPACITOR TYPE	SERIES	APPLICATIONS
<b>3-PHASE AC FILTERING</b>	<b>Modulo XD - 416.46</b>	3-phase filter/PFC for wind generator / AC filters
<b>GENERAL PURPOSE</b>	<b>GP 42 - 416.42</b>	switching, high performance lighting, UPS filter, AC-link, resonant circuit, PFC with high harmonics, DC-link, filter
	<b>GP 84 - 416.84</b>	
<b>HIGH-DENSITY / HIGH-TEMPERATURE DC APPLICATION</b>	<b>DCH 85C - 416.85.V/H</b>	High-Density / High-Temperature DC-Link, Filtering and Storage
	<b>DCH 86 PS - 416.86.V/H</b>	
<b>DC APPLICATION</b>	<b>DC 82 P - 416.82</b>	DC-link, filtering and storage
	<b>DC 85 C/B - 416.85</b>	
	<b>DC 86 P - 416.86</b>	
	<b>DC 86 PS - 416.86</b>	
	<b>DC89 HC - 416.89</b>	
	<b>DC 88 M - 416.88</b>	
	<b>DC 45 - 415.45</b>	

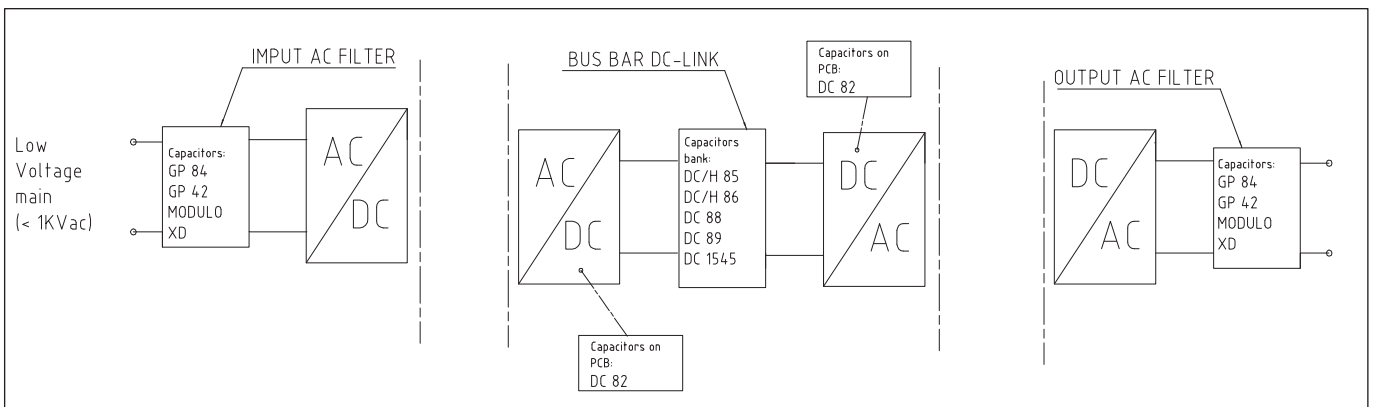

# POWER ELECTRONICS CAPACITORS

## CROSS REFERENCE TABLE

Rated DC / AC voltage (V) versus Capacitance (µF)

	DC rated voltage Un [V]	400 - 800	800 - 1400	1400 - 2000	2000 - 2500	2500 - 3000	3000 - 4000	4000 - 6000
	AC rated voltage Urms [V]	250 - 550	690 - 930	-	-	-	-	-
<b>CAPACITANCE Cn [µF]</b>	<b>0 - 50</b>	DC82 P GP42 GP84 XD	DC89 HC DC82 P GP42 GP84 XD	DC89 HC		DC85 B	DC85 B	DC85 B
	<b>50 - 100</b>	DC89 HC DC82 P GP42 GP84 XD	DC89 HC GP84 XD	DC85 C		DC85 B	DC85 B	DC86 P
	<b>100 - 150</b>	DC89 HC GP84 XD	DC89 HC DC85 C GP84	DC85 C	DC85 B	DC85 B		DC86 P
	<b>150 - 200</b>	DC89 HC GP84	DC89 HC DC 85 C GP84	DC85 C	DC85 B	DC85 B	DC86 P	DC86 P
	<b>200 - 250</b>	DC89 HC GP84		DC85 C	DC85 B		DC86 P	DC86 P
	<b>250 - 300</b>	GP84	DC85 C	DC85 C			DC86 P	
	<b>300 - 400</b>	DC85 C GP84	DC85 C	DC85 C			DC86 P	
	<b>400 - 500</b>	DC85 C GP84	DC85 C	DC85 C		DC86 P	DC86 P	
	<b>500 - 600</b>	DC85 C GP84	DC85 C	DC85 C		DC86 P		DC45
	<b>600 - 1000</b>	DC85 C	DC85 C DC85 B	DC85 C DC86 P	DC86 P	DC86 P	DC86 P	DC45
	<b>1000 - 2000</b>	DC85 C DC85 B	DC85 C DC85 B DC86 P	DC86 P	DC86 P	DC88 M DC45		
	<b>2000 - 3000</b>	DC85 C DC85 B	DC85 C DC85 B DC86 P	DC86 P	DC88 M DC45			
	<b>3000 - 6000</b>	DC 85 C DC85 B DC86 P	DC85 C DC86 P	DC88 M DC88 M				
	<b>6000 - 10000</b>	DC86 P	DC86 P DC88 M DC45					
	<b>10000 - 20000</b>	DC86 P DC88 M DC45	DC88 M DC45					

DC - series: - DC Application: expressly designed for operation with DC voltage  
 GP - series: - General purpose application: designed for operation both AC and DC voltage  
 XD - series: - Three-phases capacitors for harmonic filtering applications and PFC applications

# POWER ELECTRONICS CAPACITORS

## CONTENTS:

<b><u>CONTENTS</u></b>	<b>4</b>
<b><u>INTRODUCTION</u></b>	<b>5</b>
Ducati Energia Group	5
Certifications	6
Technologies	7
Terms and definitions	7
Safety	9
Mounting and Operating Instructions	10
Disposal	10
<b><u>GENERAL SAFETY AND INSTALLATION REQUIREMENTS</u></b>	<b>11</b>
<b><u>3-PHASE AC FILTER CAPACITORS</u></b>	<b>12</b>
Modulo XD	12
<b><u>GENERAL PURPOSE CAPACITORS</u></b>	<b>15</b>
GP Series	15
GP 42 Series	16
GP 84 Series	20
<b><u>DC CAPACITORS</u></b>	<b>25</b>
NEW DHC	26
DCH 85 C Series	27
DCH 86 PS Series	32
DC 82 P Series	35
DC 85 C Series	39
DC 85 B Series	44
DC 86 P Series	47
DC 86 PS Series	50
DC 89 HC Series	53
DC 88 M Series	58
DC 45 Series	62
<b><u>INQUIRY FORM</u></b>	<b>64</b>

# POWER ELECTRONICS CAPACITORS

## CAPACITOR EXCELLENCE SINCE 1926

In 1926 Ducati has been among the first to start industrial production of capacitors, and has been a market leader ever since.

Since its foundation, Ducati Energia has always been in the forefront of technical and industrial development, leading the research shaping today's technology and cooperating to the upgrades and improvements leading to the current IEC and EN Standards for Capacitors.

Ducati Energia firstly introduced the Metallised Polypropylene Film technology and it's innovative PPM and PPMh film set the reference for this technology, outclassing the obsolete paper/oil and gas technology in terms of superior performance and reduced dimensions.

Constantly driven to quality, environmental engagement and safety, Ducati Energia is fully certified following ISO 9001:2008, ISO 14001 and OHSAS 18001.

Today the Ducati Energia Group counts approx. 800 employees working in 6 plants:

- Ducati Energia (Bologna - Italy)
- Ducati Energia Romania (Busteni - Romania)
- Ducati Komponenti (Ludbreg - Croatia)
- Ducati Energia India (Pune - India)
- C.R.D. Centro Ricerche Ducati (Trento - Italy)
- Ducati Energia Sud America (Buenos Aires - Argentina)

Ducati Energia Group main fields of activities are:

- Motor Lighting Capacitors
- Power Electronics Capacitors
- Power Factor Correction Capacitors and Systems (LV and MV)
- Alternators and Ignition Systems
- Wind Power Generators
- Electrical Vehicles and Charging Stations for Electrical Vehicles
- Energy Analysers
- Control Systems for energy grids
- Railways Signalling systems
- Ticketing and Transport Automation systems

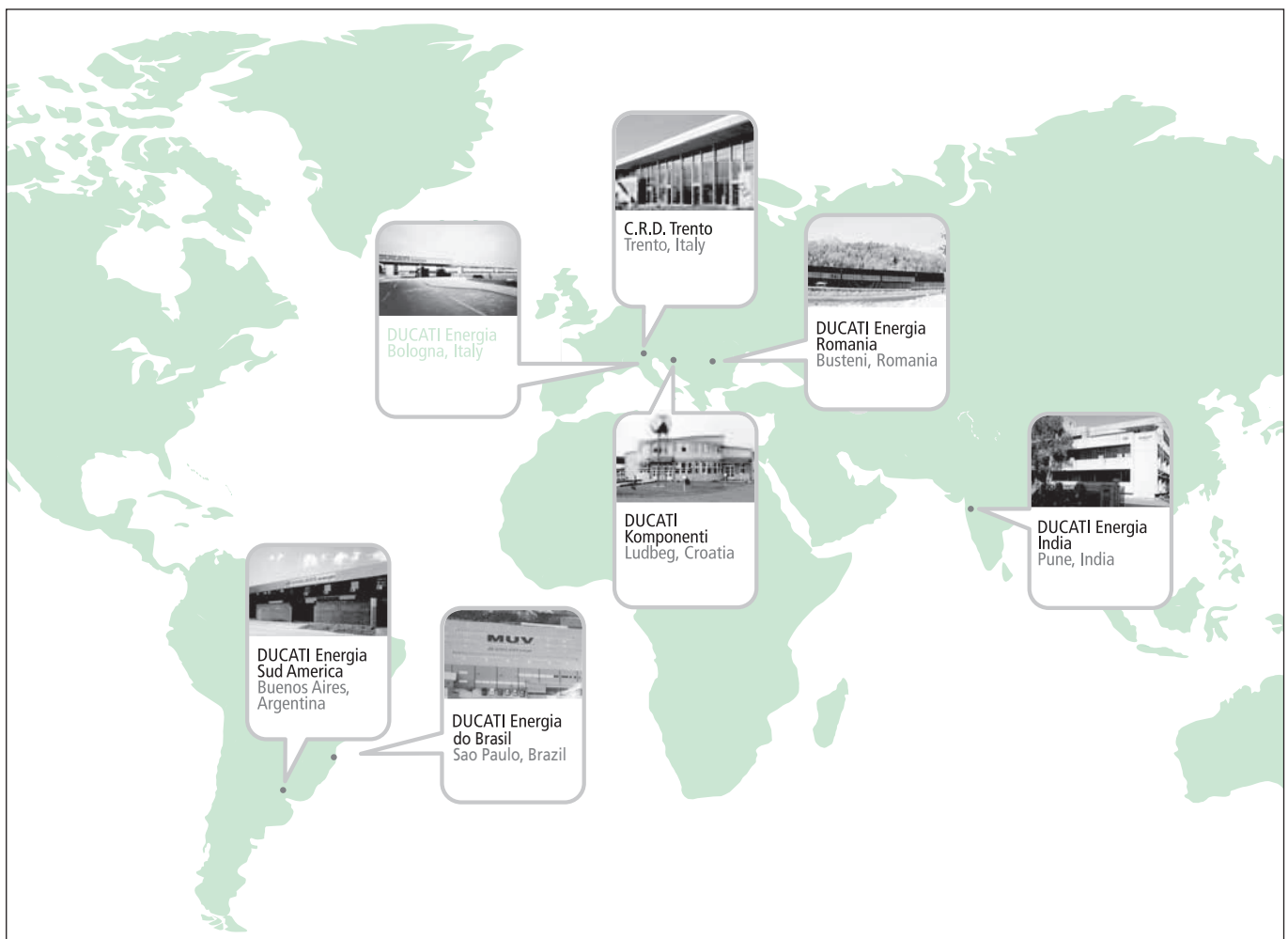

# POWER ELECTRONICS CAPACITORS

The great attention to the product Quality and to the customer service are constants in DUCATI's history and these are main factors which contribute to its success all over the world.

Ducati ha always been one of the first companies, in its field, in Italy and in Europe to adopt the most modern standards and procedures in order to assure the highest level of the quality and reliability of products.

Constantly driven to quality, environmental engagement and safety, Ducati Energia is fully certified following ISO 9001:2008, ISO 14001 and OHSAS 18001.

High quality standards are provided thanks to Ducati's innovative technologies. Its new equipment and machineries, its production control over processes based on accurate specifications and operative management skills assure the best performances.



Certification of Quality Management System ISO 9001:2008



Certification of Environmental Management System ISO 14001:2004



Certification of Occupational Health and Safety Management System BS OHSAS 18001:2007



# POWER ELECTRONICS CAPACITORS

## INTRODUCTION:

Ducati was founded in 1926 and was the first company in Italy, and among the first in the world, to introduce capacitors for the radiobroadcasting equipment produced by Guglielmo Marconi.

Building upon this tradition, which has always seen Ducati in the forefront of capacitor technology, the company has developed **the innovative PPMh (AC applications) and PPMd films (DC applications).**

Superior performance and reduced dimensions compared to the by now obsolete paper and oil and gas solutions make these capacitors the new standard of reference for industrial power electronics systems.

However, the present range also includes traditional PPM versions for applications where the capacitor is not subjected to severe working conditions.

All the capacitors manufactured by Ducati Energia feature a protection device conforming to standards IEC 61071-1/2. This protection has been achieved by means of a special engineering technology: if a fault occurs the connections will be broken due to overpressure, leaving the insulation of the case intact and preventing the capacitor from exploding or burning.

The device has been designed and dimensioned to ensure more efficient, prompt operation with both low and high short circuit currents (up to 10,000 A).

## TECHNOLOGIES

### PPM / MKP TECHNOLOGY

Metallized polypropylene technology (PPM – MKP) utilizes a vacuum evaporation technique to deposit an extremely thin layer of metal on one side of the polypropylene film.

The capacitor elements built using this technology are obtained by winding two polypropylene films. The capacitor plates consist in the metallized surface of the two films and the dielectric is the propylene film itself.

The main advantage of capacitors with metallized plates is their self-healing capacity. This means that they are capable of restoring their electrical properties following the occurrence of a short circuit between the plates. Due to the reduced thickness of the plates, the short circuit current generated in the area of a fault is capable of vaporizing the metal coating; the short circuit is thereby automatically extinguished without an appreciable reduction in capacitance or expenditure of energy.

### PPMh AND PPMd TECHNOLOGY

The continuous research conducted in Ducati Energia laboratories has led to the development of a polypropylene film with a special metallization, whose purpose is to increase gradient of voltage without decreasing lifetime. Thanks to this innovative metallization treatment, the capacitor has a significantly dimension reduction and maintains its dielectric properties and performance in terms of both current and voltage:

- PPMh is film designed for AC voltage, can support also DC applications, agree with technical data;
- PPMd is designed for DC voltage, with high superimposed ripple.

### PPMdh HIGH DENSITY / HIGH TEMPERATURE TECHNOLOGY

The latest development of Ducati Energia research is a particularly crystalline film with a special metallization type. The result is a superior capability in terms of voltage gradient and temperature stability. PPMdh therefore provides:

- Up to +25% capacity in the same volume
- Up to +20°C Operating Temperatures, without current or lifetime derating

## TERMS AND DEFINITIONS

(According to IEC 61071)

### Rated capacitance (Cn)

Capacitance value rated at ambient temperature ( $20 \pm 5^\circ\text{C}$ ) and at the rated voltage. For capacitors made with metallized polypropylene dielectric film, the capacitance and dissipation factor change versus temperature. Typical graphs of these deviations are shown in the below diagrams.

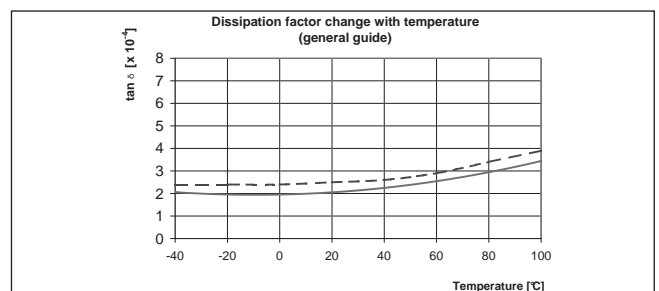
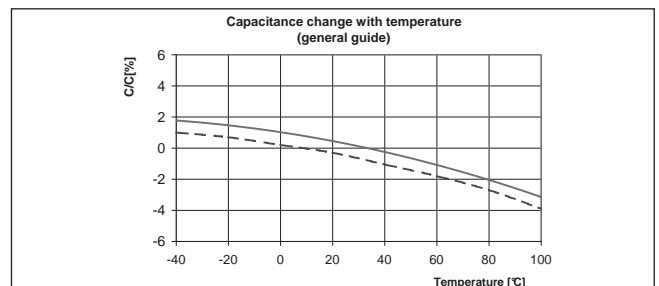

### Tolerance on capacitance

The maximum admitted deviation from the rated value of capacitance, measured at ambient temperature ( $20 \pm 5^\circ\text{C}$ ) and at the rated voltage.

### Rated AC Voltage (Un AC)

The maximum operating peak recurrent voltage of either polarity of a reversing type wave form, for which the capacitor has been designed.

### Rated DC Voltage (Un DC)

The maximum operating peak voltage of either polarity but of a non-reversing type wave form, for which the capacitor has been designed.

# POWER ELECTRONICS CAPACITORS

## Rated Rms voltage (Urms)

Root mean square of the maximum permissible value of A.C. voltage, in continuous operation. In case of sinusoidal wave form voltage, the following relationship could be considered:

$$U_N = U_{rms} \cdot \sqrt{2}$$

## Non-recurrent surge voltage (Us)

A peak voltage induced by switching or any other faults or disturbance of the system, which is allowed for a maximum of 500 times and for a durations shorter than 100 msec.

## Ripple voltage (Ur)

The peak-to-peak alternating component of the unidirectional voltage.

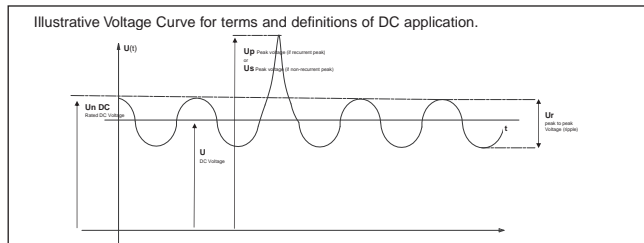
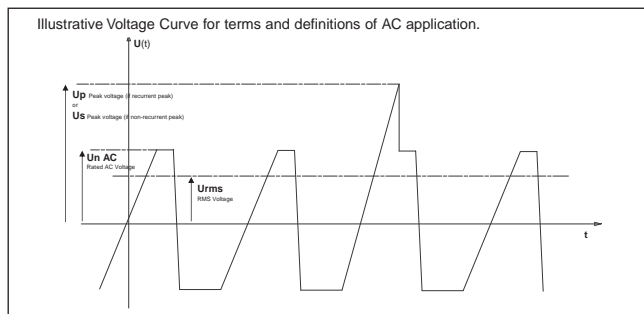

## Maximum current (Imax)

The maximum rms value of permissible current in continuous operation. This value is related to the maximum power dissipation at the highest permitted temperature of the case ( $\theta_{max}$ ) at which the capacitor may be operated. Operating at the maximum r.m.s current (IMAX), the capacitor produces a case temperature rise of about 10 – 15 °C over the ambient, according to the capacitor type (please see RTHC for each models) and the application.

To avoid thermal instability on the capacitor the case temperature of the capacitor must not exceed the maximum operating temperature ( $\theta_{max}$ ), so it could be necessary to reduce the ambient temperature with a cooling air system or to reduce the Imax current.

## Maximum peak current (Ipk)

The maximum current amplitude which occurs instantaneously during continuous operation. For some capacitors series and according to the typical application (high or low distortion), it's possible to describe two different maximum peak current:

**Ipk Cw (continuous waveform):** for linear or low distortion current waveform - picture 1

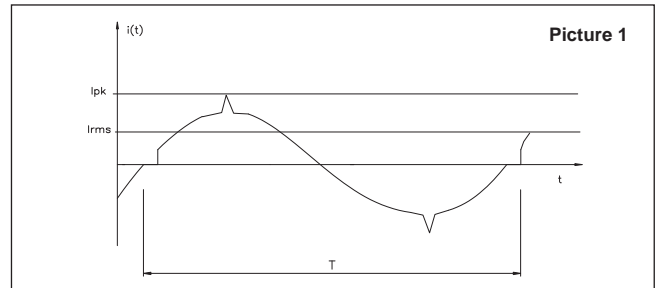

**Ipk Iw (Impulsive waveform):** for high distortion current waveform, typical when the  $t_o/T < 0,1\%$  - picture 2

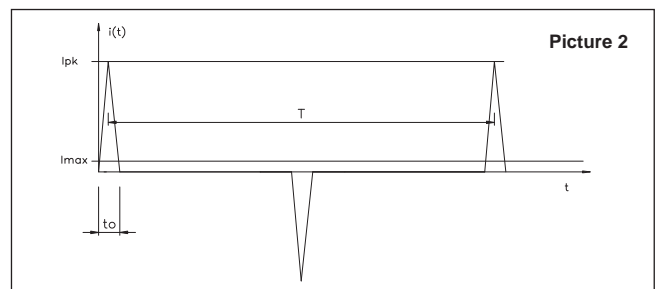

Rate of voltage rise (du/dt)

Maximum permitted repetitive rate of voltage rise of the operational voltage

## Peak surge current (Is)

The admissible peak current induced by switching or any other faults or disturbance of the system, which is allowed for a maximum of 500 times and for a durations shorter than 100 msec.

## Equivalent series resistance (RESR)

An effective resistance which, if connected in series with an ideal capacitor with the same value capacitance, would have a power loss equal to the active power dissipated in the capacitor under specified operating conditions. Normally, for frequency lower than the resonanting one, the following relationship could be considered:

$$R_{ESR} = R_s + \left( \frac{\tan \delta_0}{2\pi f C} \right)$$

## Series resistance (Rs)

It is the resistance produced by the current heat losses  $I_{RMS}^2 \cdot R_s$  in the capacitor.

## Equivalent series inductance (LESR)

The value of equivalent inductance that the capacitors has due to the internal connections, terminals, winding characteristics and physical dimensions.

## Thermal resistance (RTHC)

It is the thermal resistance (°C/W) between the hottest point on the case of the capacitor in thermal equilibrium and the natural cooling environment, with the temperature measured approximately at 0,1 meter away from the capacitor container and at two-third of the height from its base. The following relationship could be considered:

$$P_{max} = \frac{1}{R_{THC}} (\theta_c - \theta_{max})$$



# POWER ELECTRONICS CAPACITORS

## Maximum dissipation factor ( $\tan \delta$ max)

Maximum tangent of the loss angle, expressed as the ratio between the equivalent series resistance and the capacitive reactance of the capacitor at 50Hz sinusoidal frequency. The nominal value ( $\tan$ ) is calculated as follows:

$$\tan \delta = 2\pi f C R_{ESR} = \tan \delta_0 + 2\pi f C R_s$$

## Safety area

The following charts shown the maximum permissible voltage or current in case of an overload operation. The amplitude of overvoltages or overcurrents may be tolerated without significant reduction in the life time of capacitor, if the case temperature of the capacitor is within the operating temperature.

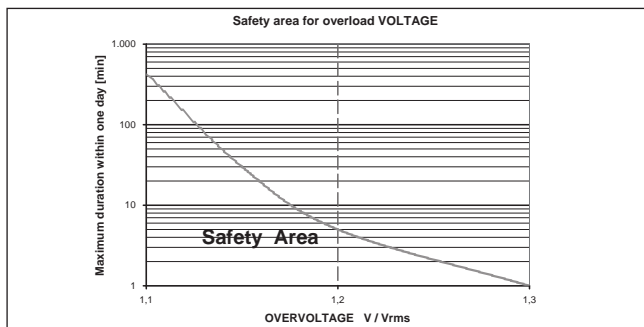
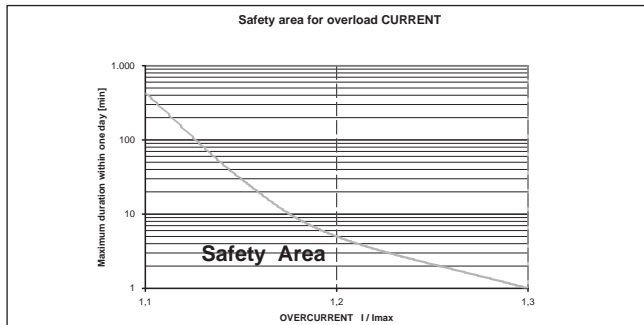

## Voltage test between terminals ( $U_{tt}$ )

Routine test of all capacitors conducted at room temperature, prior to delivery. The capacitor shall be subjected for 10 s to a test voltage applied between the terminals. During the test, neither puncture nor flashover shall occur, self-healing breakdowns are permitted. For more details regarding the value of test voltage, please see the data sheet for each single capacitor model.

## Voltage test between terminals and case ( $U_{tc}$ )

Routine test of all capacitors conducted at room temperature, prior to delivery. The capacitor having all terminals insulated from the container shall be subjected for 10 s to a AC test voltage applied between terminals (joined together) and the container. During the test, neither puncture nor flashover shall occur. For more details regarding the value of test voltage, please see the data sheet for each single capacitor model.

## Lowest operating temperature ( $\theta$ min)

Lowest permissible case temperature, in thermal equilibrium, at which the capacitor may be used.

## Maximum operating temperature ( $\theta$ max)

Highest permissible case temperature, in thermal equilibrium, at which the capacitor may be used.

## Climatic categories

F class:

- maximum relative humidity 75% - annual means,
- permitted maximum 95% for 30 days/year,
- condensation not permitted

## SAFETY

## Capacitor Protection:

### - Against accidental contact

In accordance with IEC 61071, all capacitors are checked by 100% routine test (voltage test between terminations and case). Accessible capacitors must be earthed at the bottom stud or with an additional earthing clamp.

### - Overload and failure at the end of service life

All described capacitors are "self-healing": in the event of a voltage breakdown the metal layers around the breakdown channel are evaporated by the temperature of the electric arc between the electrodes, and create small overpressure. An insulation area is formed which is reliably resistive and voltage proof for all operating requirements of the capacitor. The capacitor remains fully functional during and after the breakdown.

In the event of overvoltage or at the end capacitor service life, an increasing number of selfhealing breakdowns may cause rising pressure inside the capacitor and brake the can. To prevent it, the capacitor is fitted with an obligatory "overpressure mechanism".

This safety mechanism is based on an attenuated spot at one of the connecting wires inside the capacitor.

When the rising pressure, the casing begins to expand, and disconnects the attenuated spot wire and the current path is interrupted irreversibly. It has to be noted that this safety system can act properly only within the permitted limits of loads and overloads.

The capacitors in rectangular case are provided with an overpressure switch that would signalize a rising pressure inside the case. A corresponding external safety circuit which disconnects the capacitor immediately in such event has to be provided by the user.

### - Overvoltages and Short Circuits

As shown above, the capacitors are self-healing and regenerate themselves after breakdowns of the dielectric. For voltages within the permitted testing and operating maximum the capacitors are overvoltage-proof.

They are also proof against external short circuits as far as the resulting surge discharges do not exceed the specified current limits (IS).

## Operating life

The capacitors have been designed for an average service life of 100,000 hrs (with 50 fit permitted).

Above all, the operating life of the capacitors depends on the temperature inside during operation, and the field strength in its dielectric.

The following diagram demonstrates the correlation between service life, hot spot temperature, and operating voltage.

# POWER ELECTRONICS CAPACITORS

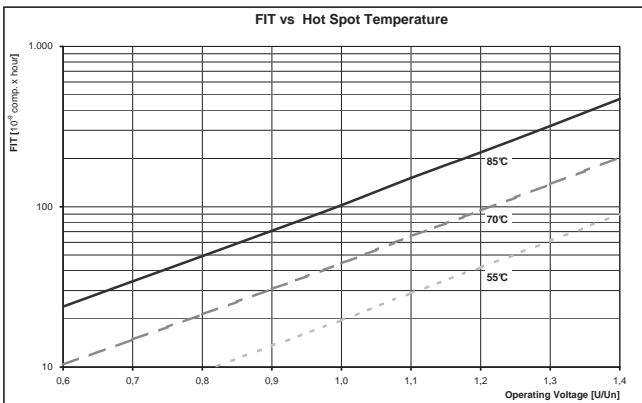
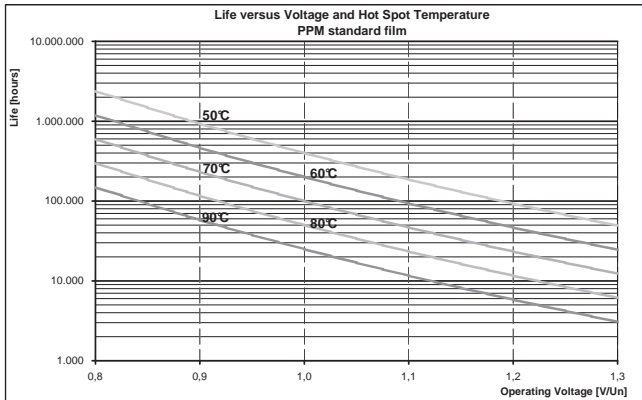

## MOUNTING AND OPERATING INSTRUCTIONS

### Connection

Connection at threaded studs have to be made between two nuts. It is not recommended to solder cables to the terminals. Permitted torque for screw connections.

See individual data sheets for each range.

### Capacitors overpressure device:

All the AC capacitors with overpressure device shall be connected with sufficiently flexible leads to permit the functioning of the mechanism, and sufficient space for expansion of the capacitor case must be left above the terminals.

Depending on the specific dimensions of the capacitors the case could expand between 15 mm and 30 mm.

### Mounting Location

As mentioned, the useful life of a capacitor may be reduced dramatically if exposed to excessive heat. To avoid overheating the capacitors must be allowed to emit their heat losses unhindered and shall be shielded from external heat sources. If attenuating circumstances give cause for doubt, special tests should be conducted to ensure that the permitted maximum temperature of the capacitor is not exceeded even under the most critical ambient circumstances. It should be noted that the internal heat balance of large capacitors is only reached after a couple of hours.

### Mounting position

Capacitors with liquid or viscous filling shall be installed upright with terminals facing upwards. Please consult our technical department if different mounting position

is required. Capacitors with hard resin filling can be mounted in any position without restrictions.

### Earthing

Capacitors with a metal case must be earthed at the mounting stud or by means of a separate metal strap or clamp.

### Discharge

If there is no discharge of the capacitors provided by external circuits, the capacitors should be provided with discharge resistors. In any event, the poles of the capacitors must be short-circuited before being touched. Note that capacitors with nominal voltages above 750 V in particular may regenerate new voltage at their terminals after having been short-circuited just for short periods. This condition results from the internal series connection of the capacitor elements and will be avoided by storing them permanently short-circuited.

## DISPOSAL

Our capacitors do not contain PCB, solvents, or any other toxic or banned materials. The impregnants and filling materials contain vegetable oil or polyurethane mixtures. The capacitors are not rated as hazardous goods in transit and do not have to be marked under the Regulations for Hazardous Goods. They are rated WGK 0 (water risk category 0 "no general threat to water"). We recommend disposing of the capacitors through professional recycling centres for electric/electronic waste. The capacitors can be disposed of as follows:

- Capacitors: acc. to European Waste Catalogue (EWC) No. 160216 ("Components taken from discarded equipment")
- Liquid filling materials: acc. to EWC No. 080402 ("Waste adhesives and sealants free of halogenated solvents")
- Hardened filling materials: acc. to EWC No. 080404 ("Hardened adhesives and sealants").

Caution: When touching or wasting capacitors with activated break-action mechanism, please consider that even after days and weeks these capacitors may still be charged with high voltages !

Capacitors are hermetic sealed, to maintain a long operating life and for the correct functioning of the break action mechanism, please pay special attention not to damage any parts of the can, cover or isolators.

### NOTE:

Capacitors of the DC series are not provided with an internal safety mechanism which would separate them in a controlled and reliable manner from the energy supply in case of malfunctioning.

These capacitors consist mainly of polypropylene (up to 90%), i.e. their energy content is comparably high. Capacitors may rupture and ignite as a result of internal faults or external overload (e.g. temperature, overvoltage, harmonic distortion). It must therefore be ensured by proper measures that they not perform any hazard for their environment in the event of failure. Energy content in case of fire: approx. 40 MJ/kg.

# Power Electronics Capacitors

## GENERAL SAFETY RECOMMENDATIONS

### I. SCOPE

These safety recommendations and requirements apply to the following power electronics capacitors and standards. Their purpose is to describe the state of technology which must as a rule be adhered to in all relevant contracts for goods and services.

- 1) Capacitors for power IEC / DIN EN 61071 electronics (PEC).
- 2) Capacitors for railway IEC / DIN EN 61881 applications (PEC).

### II. GENERAL SAFETY RULES

Since power capacitors are electrical energy storage devices, they must always be handled with caution. Even after being turned off for a relatively long period of time, they can still be charged with potentially lethal high voltages.

### III. GENERAL CONDITIONS FOR STORAGE AND USE

- 1) The manufacturer's installation, application and maintenance instructions **and** the relevant standards must always be complied with.
- 2) **Capacitors must never be stored or used outside the specified temperature ranges.**
- 3) Capacitors may not be stored or operated in corrosive atmospheres, particularly not when chlorides, sulfides, acids, alkalis, salts, organic solvents or similar substances are present.
- 4) **The maximum temperatures (including inherent heat) voltages, currents, power, reactive power, thermal resistances, frequencies, discharge times and switching frequencies specified in the data sheet must be adhered to.**
- 5) **A means of sufficient dissipation of heat loss (fan, cooling) or escaping gases in case of malfunction must be provided. Required minimum distances (e.g. to sources of heat) must be maintained.**
- 6) Specified torques for electrical connections and fasteners must be adhered to.
- 7) Mechanically or electrically damaged, leaky or otherwise damaged capacitors may not be used or continue to be used.
- 8) Existing protective devices of the capacitors may not be manipulated, removed or impaired in their function.

### IV. INTERNAL PROTECTIVE DEVICES

- 1) Internal protective devices offer basic protection against certain internal faults, aging and overload.
- 2) Internal protective devices alone are not sufficient to prevent all conceivable dangers in case of malfunction. The so-called self-healing capability is not the same as fail safe system stability.
- 3) Depending on their protective mechanism, internal protective devices are subject to technical and functional limits which when exceeded will definitely cause malfunctions. Such violations can be **excess temperature, overvoltage, wrong application, wrong installation, faulty maintenance, mechanical damage, or operation outside the technical limits of the specification.**
- 4) Most internal protective devices can interrupt the voltage only within the capacitor. They are not fuses in the classical sense such as cable or device fuses which interrupt the voltage upstream from the faulty system component.

### V. RISK FACTORS FOR THE CAPACITOR

The most frequent risk factors which cause capacitor damage and possibly also the failure of the internal protective devices are:

- 1) Exceeding the permissible temperature on the capacitor surface (a continuous increase temperature of 7 K cuts life expectancy in half).
- 2) Over voltages, over currents and high inrush currents even if they only occur briefly or cyclically (a continuous increase in the operating voltage of the capacitor of 8% cuts life expectancy in half).
- 3) Network harmonics, resonances created by harmonics or flicker even when they occur only briefly or cyclically.
- 4) Aging of the lighting equipment and consequential excess temperature or high UV stress.
- 5) Failure of other components in a common circuit and consequential over voltages or over currents.
- 6) Interaction with other reactive power components, and also parasitic capacitances (cable) or inductivities in common circuits.
- 7) Even if the test based on the capacitor standard is passed, this does not ensure comprehensive protection against all possible overloading.
- 8) During the operation of thyristor-switched capacitor system, high DC voltages can occur continuously on the capacitors of compensation systems which are not switched on. These DC voltages must be considered when designing the capacitors and the discharge devices.

### VI. RISKS WHEN A FAULT OCCURS

- 1) Power capacitors can be a significant risk in the case of failure due to their stored energy and/or their properties during operation in networks with high short-circuit power.
- 2) Power capacitors can actively fail when internal or external protective devices are missing, incorrectly dimensioned or have failed. They can burst, burn or, in extreme cases, explode.

### VII. RISK MINIMIZATION

- 1) The capacitor manufacturer cannot predict all possible stresses which a power capacitor can be subjected to and which must be taken into account in the design. This means that the user bears crucial co-responsibility here. For this reason alone, safety and quality should be the top priorities when a capacitor is selected. **This is why we urgently recommend the use of capacitors with appropriate internal protective devices.**
- 2) Before designing the application, capacitors must be checked for their suitability for this particular application. All influences (parameters) must be considered. Unexamined use in an application may have serious consequences. Particularly with sensitive applications, the internal protective devices of the capacitors should be supplemented by the user with suitable external protective measures. **External protective measures are even mandatory when capacitors are used without internal protective devices.**
- 3) When power capacitors are used, suitable measures must always be taken to eliminate possible danger to humans, animals and property both during operations and when a failure occurs. This applies to capacitors both without and with protective devices.



## Power Electronics Capacitors

# 3-PHASE AC FILTER CAPACITORS

### Modulo XD series

Metallized polypropylene three-phases capacitors for harmonic filtering applications and power factor correction applications.

- Aluminum case
- Dry resin
- Self-healing polypropylene metallized film
- Overpressure safety device
  
- PFC with high AC voltage and high rms and surge current harmonics filtering
- Wind turbines



Rated voltage	AC 450 ÷ 800 V (*)
Capacitance range	1 ÷ 250 µF (*)
Capacitance tolerance	- 5% / +10%
Test voltage between terminals	2,15 x Urms - 2s
Test voltage between terminals and case	3,0 KVac 50 Hz - 10s
Temperature class	-40 / D (max 55 °C)
Protection degree	IP 20 (IP54 on request)
Hot spot temperature	85 °C
Voltage raise (dV/dt)	110 V/us
Dielectric losses (tan δo)	0,2 W/kVAr
Typical total losses (tan δ)	0,55 W/kVAr
Maximum cable section	25 mmq
Three-phase connection	Delta
Filling	Dry polyurethane resin
Dielectric	Metallized polypropylene film
Case	Aluminum
Life expectancy	100.000 h (**)
Failure quota	50/10E9
Installation	Vertical / horizontal
Reference standard	IEC 1071-1/2; UL 810
UL-CSA approved (UL <sup>®</sup> US)	File n. 192559
M4 screw clamp terminals	Max 1,5 Nm
M12 fixing bolt	Max 10 Nm

(\*) Standard values, other values on request.

(\*\*) For details please refer to page 10

# Power Electronics Capacitors

## 3-PHASE AC FILTER CAPACITORS

### XD Series

Capacitance 3x Cn [µF]	Dimension (ØxH) [mm]	RMS Current I <sub>RMS</sub> [A]	Repet. Peak Current Ip [kA]	Surge Current Is [kA]	Series Resistance Rs [mΩ]	Inductance Ls [nH]	Thermal Resistance R <sub>THC</sub> [°C/W]	Typical Weight [kg]	Pcs. / box	Box type	Part number 416.46.xxxx
<b>U<sub>rms</sub> = 450V</b>			<b>U<sub>n AC</sub> = 640V</b>			<b>Surge Voltage [Us] = 1380 V</b>					
3x 7,9	65 x 165	10	0,3	0,9	5,90	120	5,8	0,65	14	E	3020
3x 13	65 x 165	10	0,5	1,4	5,90	120	4,3	0,65	14	E	3030
3x 26	75 x 165	14	1,0	2,9	5,90	120	2,2	0,80	12	F	3050
3x 39	75 x 255	20	1,6	4,3	4,04	150	1,9	1,25	6	F	3080
3x 52	75 x 255	27	2,1	5,7	3,03	150	1,9	1,60	6	F	3100
3x 66	85 x 255	34	2,6	7,3	2,64	150	1,6	1,60	6	F	3150
3x 79	90 x 255	40	3,2	8,7	2,20	150	1,4	1,80	6	F	3200
3x 104	100 x 255	54	4,2	11,4	1,65	150	1,1	2,25	6	G	3260
3x 131	116 x 255	55	5,2	12,0	2,15	150	0,9	2,85	6	H	3310
3x 157	116 x 290	55	6,3	12,0	2,58	180	0,8	3,30	6	H	3360
3x 235	116 x 370	65	9,4	14,0	2,72	200	0,7	4,20	4	I	3375
<b>U<sub>rms</sub> = 500V</b>			<b>U<sub>n AC</sub> = 710V</b>			<b>Surge Voltage [Us] = 1530 V</b>					
3x 6,3	65x165	10	0,3	0,7	5,90	120	5,8	0,65	14	E	4020
3x 10,5	65x165	10	0,4	0,1	5,90	120	4,3	0,65	14	E	4030
3x 21	75x165	12	0,8	2,3	5,90	120	2,2	0,80	12	F	4050
3x 32	75x255	18	1,3	3,5	4,99	150	1,9	1,25	6	F	4080
3x 43	75x255	24	1,7	4,7	3,74	150	1,9	1,60	6	F	4100
3x 53	85x255	30	2,1	5,8	3,27	150	1,6	1,60	6	F	4150
3x 64	90x255	36	2,6	7,0	2,72	150	1,4	1,80	6	F	4200
3x 85	100x255	49	3,4	9,4	2,04	150	1,1	2,25	6	G	4260
3x 106	116x255	55	4,2	11,7	2,15	150	0,9	2,85	6	H	4310
3x 127	116x290	55	5,1	12,0	2,58	180	0,8	3,30	6	H	4360
3x 190	116 x 370	65	8,5	14,0	2,72	200	0,7	4,20	4	I	4375
<b>U<sub>rms</sub> = 550V</b>			<b>U<sub>n AC</sub> = 780V</b>			<b>Surge Voltage [Us] = 1680 V</b>					
3x 5,1	65x165	10	0,2	0,6	6,50	120	5,8	0,65	14	E	5020
3x 8,5	65x165	10	0,3	0,9	6,50	120	4,3	0,65	14	E	5030
3x 17	75x165	11	0,7	1,9	6,50	120	2,2	0,80	12	F	5050
3x 25	75x255	17	1,0	2,8	6,04	150	1,9	1,25	6	F	5080
3x 34	75x255	22	1,4	3,7	4,53	150	1,9	1,60	6	F	5100
3x 43	85x255	28	1,7	4,7	3,95	150	1,6	1,60	6	F	5150
3x 52	90x255	33	2,1	5,7	3,29	150	1,4	1,80	6	F	5200
3x 70	100x255	44	2,8	7,7	2,47	150	1,1	2,25	6	G	5260
3x 87	116x255	55	3,5	9,6	2,15	150	0,9	2,85	6	H	5310
3x 105	116x290	55	4,2	11,6	2,58	180	0,8	3,30	6	H	5360
3x 158	116 x 370	65	7,6	14,0	2,72	200	0,7	4,20	4	I	5375
<b>U<sub>rms</sub> = 690V</b>			<b>U<sub>n AC</sub> = 980V</b>			<b>Surge Voltage [Us] = 2110 V</b>					
3x 22	75x255	18	0,9	2,4	5,83	150	1,9	1,60	6	F	6100
3x 28	85x255	22	1,1	3,1	4,66	150	1,6	1,60	6	F	6150
3x 33	90x255	26	1,3	3,6	4,75	150	1,4	1,80	6	F	6200
3x 45	100x255	35	1,8	5,0	3,56	150	1,1	2,25	6	G	6260
3x 56	116x255	44	2,2	6,2	2,85	150	0,9	2,85	6	H	6310
3x 67	116x290	53	2,7	7,4	2,59	180	0,8	3,30	6	H	6360
<b>U<sub>rms</sub> = 800V</b>			<b>U<sub>n AC</sub> = 1140V</b>			<b>Surge Voltage [Us] = 2440 V</b>					
3x 17	75x255	15	0,7	1,9	7,84	150	1,9	1,60	6	F	8100
3x 21	85x255	19	0,8	2,3	6,27	150	1,6	1,60	6	F	8150
3x 25	90x255	23	1,0	2,8	6,39	150	1,4	1,80	6	F	8200
3x 33	100x255	30	1,3	3,6	4,79	150	1,1	2,25	6	G	8260
3x 41	116x255	38	1,6	4,5	3,83	150	0,9	2,85	6	H	8310
3x 50	116x290	46	2,0	5,5	3,48	180	0,8	3,30	6	H	8360

NOTES:  
 (Cn) Tolerance standard value: -5% / +10%. Other tolerance values on request.  
 (Cn) - (Ums) Capacitance and rated voltage standard values, other values on request.  
 (Rs) Releated at 1 KHz.  
 (R<sub>THC</sub>) Thermal resistance natural cooling, AMBIENT to CASE.  
 (I<sub>RMS</sub>) RMS Current @ 45 °C ambient temperature.  
 On request, external box discharge resistor (not available for series 690 V - 800 V).



# Power Electronics Capacitors

## 3-PHASE AC FILTER CAPACITORS

### Safety system:

Dimension with overpressure device activated.

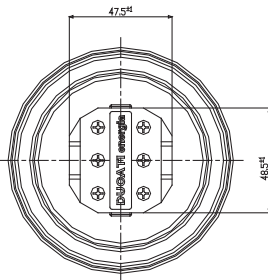
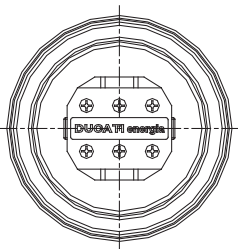
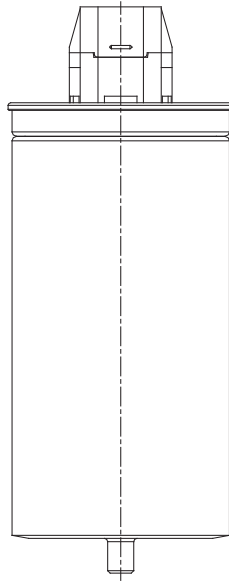
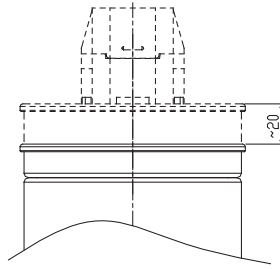
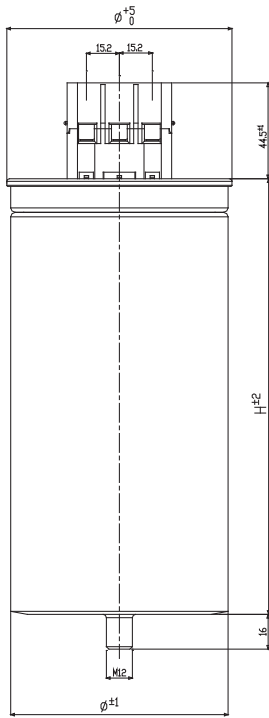

### Safety system:

Overpressure protection device. To enable the device to operate efficiently, it is necessary to leave a gap of at least 30 mm above the element and use flexible leads for the connection.

### Box TYPE

Standard box dimensions:

E	195 x 390 x 255 mm
F	185 x 290 x 270 mm
G	225 x 340 x 270 mm
H	330 x 340 x 225 mm
I	270 x 270 x 450 mm

Capacitor diameter (Ø) [mm]	Terminal cover CODE	Terminal cover (Ø MAX) [mm]	Pcs. x box
85	316523338	94	30
90	316523339	99	30
100	316523340	109	30
116	316523341	125	30

External box discharge resistor (not available for series 690V - 800V)

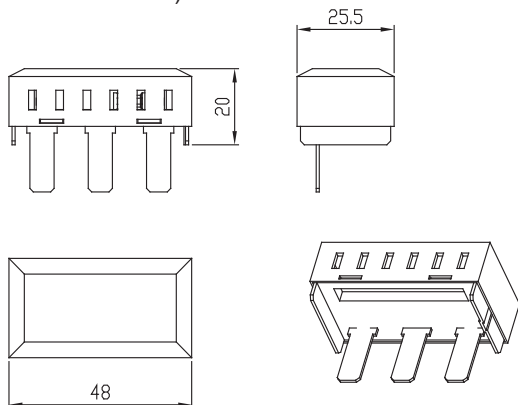

Terminal cover IP54 when properly used (\*)

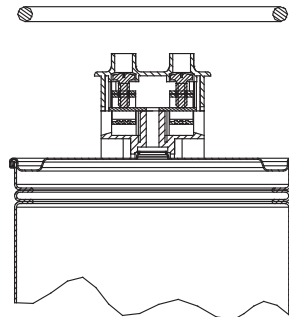
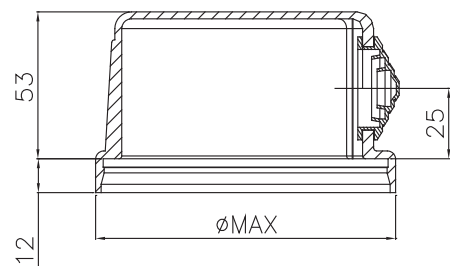

(\*) Only for capacitor diameter  $\geq 85$  mm





## Power Electronics Capacitors

# GENERAL PURPOSE CAPACITORS

## GP SERIES

Metallized Polypropylene AC and DC capacitors for power electronics application with high current and harmonics distortion with long expected life.

### FEATURES

- Cylindrical aluminum case
- Over pressure device
- Dry resin
- Double/single tags or screw type bolts terminals
- Self healing PPM/PPMh dielectric
- AC / DC voltage applications

### TYPICAL APPLICATIONS

- Inverter
- Filtering
- Switching
- High power lighting



<i>GENERAL CHARACTERISTICS</i>	
RMS Voltage range	250 - 1000V (*)
DC Voltage range	420 - 2100V (*)
Rate Capacitance	0,1÷600 µF
Test voltage between terminals	1,5 Un 10s
Test voltage between terminals and case	3 kV 50 Hz 10s
Terminals	Single or double tag 6.3 x 0.8 mm (GP 42 series) 2 x M6 or 2 x M10 screw-type bolts (GP 84 series)
Working temperature	-40 / +70°C
Storage temperature	-40 / +85°C
Protection degree	IP 00
Filling	Dry polyurethane resin
Dielectric	Self-healing metallized polypropylene film
Case	Aluminum
Protection	Over pressure device
Maximum altitude	2000 m a.s.l.
Installation	Vertical / horizontal
Reference standard	IEC 1071-1/2; UL 810
Approvals	UL-CSA  US (**)

(\*) Standard values, other values on request.

(\*\*) For GP84 series.

# Power Electronics Capacitors

## GENERAL PURPOSE CAPACITORS



### GP 42 Series

RMS Voltage range	250÷930 V
Capacitance range	0,1÷100 µF
Capacitance tolerance	±5% / ±10%
Max. RMS current	10 A / 16 A
Maximum working frequency	10 kHz
Thermal resistance natural cooling (R <sub>THC</sub> )	< 12 °C/W
Series resistance (R <sub>s</sub> )	< 5 mΩ
Terminals	Single or double tag 6,3x0,8 mm
Working temperature	-40 / +70 °C
Storage temperature	-40 / +85 °C
Test voltage	U <sub>tc</sub> = 3 kVac / 6 kVac @50 Hz 10s U <sub>tt</sub> = 1,5 x U <sub>NDC</sub> 10s
Filling	Dry polyurethane resin
Dielectric	Metallized PPM film
Cylindrical case	Aluminum
Life expectancy	80.000 h (*)
Failure quota	300/10E9
Reference standard	IEC 1071-1/2; UL 810
Integrated overpressure protection	
M8 fixing bolt	Max 5 Nm
M12 fixing bolt	Max 10 Nm

(\*) Life Derating at operating voltage (according to the chart on page 10)

Life expectancy	4.16.42.1xxx Series	4.16.42.2xxx Series	4.16.42.3xxx Series	4.16.42.4xxx Series	4.16.42.6xxx Series	4.16.42.9xxx Series
80.000 h (rated)	250 V	330 V	450 V	550 V	690 V	930 V
40.000 h	275 V	360 V	500 V	575 V	760 V	1025 V
20.000 h	300 V	400 V	540 V	630 V	830 V	1120 V
10.000 h	330 V	450 V	600 V	690 V	930 V	1250 V

# Power Electronics Capacitors

## GENERAL PURPOSE CAPACITORS

### GP 42 Series

Cn [μF]	I <sub>MAX</sub> [A]	I <sub>PK</sub> C <sub>w</sub> [A]	I <sub>s</sub> [kA]	dV/dT <sub>max</sub> [V/μs]	R <sub>THC</sub> natural cooling [°C/W]	Tan δ <sub>MAX</sub> @50Hz [10 <sup>-4</sup> ]	Ø [mm]	H [mm]	Weight [g]	Part n. 416.42.	Pcs. / box	Box type
<b>Urms = 250 V</b>				<b>Un<sub>AC</sub> = 350 V</b>			<b>Un<sub>DC</sub> = 490 V</b>		<b>Us = 840 V</b>			
2	5,0	8	0,1	50	11,7	3,5	25	60	40	1.05.x	250	6
5	6,5	10	0,3	50	9,4	4,0	30	60	50	1.23.x	200	6
10	7,5	11	0,5	45	6,8	4,5	35	72	80	1.42.x	100	7
15	8,0	12	0,7	45	5,8	5,0	40	72	100	1.55.x	100	6
20	8,5	13	0,7	30	4,5	5,5	40	98	140	1.63.x	50	7
25	8,5	13	0,8	30	4,5	5,5	40	98	150	1.68.x	50	7
30	9,0	14	1,0	30	3,9	5,5	40	98	170	1.69.x	50	7
40	10,0	15	0,9	20	3,3	6,0	45	122	220	1.82.x	25	7
50	10,0	15	1,1	20	3,3	6,0	45	122	230	1.89.x	25	7
60	10,0	15	1,3	20	2,9	6,0	50	122	270	1.92.x	25	7
70	10,0	15	1,5	20	2,6	6,5	55	122	320	1.95.x	25	6
80	10,0	15	1,5	20	2,6	6,5	55	122	330	1.97.x	25	6
100	10,0	15	1,7	15	2,1	7,0	60	137	420	1.99.x	25	6
<b>Urms = 330 V</b>				<b>Un<sub>AC</sub> = 470 V</b>			<b>Un<sub>DC</sub> = 600 V</b>		<b>Us = 1120 V</b>			
1	5,0	8	0,1	50	11,7	3,5	25	60	40	2.03.x	250	6
2	6,0	9	0,2	70	10,4	3,5	30	53	50	2.12.x	200	7
5	7,0	11	0,3	50	7,8	4,5	35	60	80	2.39.x	125	6
10	8,0	12	0,5	45	5,8	5,0	40	72	100	2.49.x	100	6
15	8,5	13	0,5	30	4,5	5,5	40	98	140	2.58.x	50	7
20	9,0	14	0,7	30	3,9	5,5	45	98	180	2.68.x	50	6
25	10,0	15	0,6	20	3,3	6,0	45	122	220	2.75.x	25	7
35	10,0	15	0,8	20	2,9	6,5	50	122	270	2.88.x	25	7
50	10,0	15	0,8	15	2,4	6,5	55	132	350	2.94.x	25	6
60	10,0	15	1,0	15	2,1	7,0	60	137	430	2.98.x	25	6
<b>Urms = 450 V</b>				<b>Un<sub>AC</sub> = 640 V</b>			<b>Un<sub>DC</sub> = 890 V</b>		<b>Us = 1400 V</b>			
1	5,0	8	0,1	50	11,7	3,5	25	60	40	3.08.x	250	6
2	6,5	10	0,1	50	9,4	4,0	30	60	50	3.29.x	200	6
5	8,0	12	0,2	45	5,8	5,0	40	72	100	3.47.x	100	6
10	8,5	13	0,3	30	4,5	5,5	40	98	140	3.58.x	50	7
15	10,0	15	0,3	20	3,3	6,0	45	122	220	3.77.x	25	7
20	10,0	15	0,4	20	2,9	6,5	50	122	270	3.88.x	25	7
25	10,0	15	0,4	15	2,4	6,5	55	132	350	3.92.x	25	6
30	10,0	15	0,5	15	2,4	6,5	55	132	360	3.95.x	25	6
35	10,0	15	0,6	15	2,1	7,0	60	137	430	3.97.x	25	6
40	10,0	15	0,7	15	2,1	7,0	60	137	440	3.99.x	25	6

# Power Electronics Capacitors

## GENERAL PURPOSE CAPACITORS

### GP 42 Series

Cn [μF]	I <sub>MAX</sub> [A]	I <sub>PK</sub> C <sub>w</sub> [A]	I <sub>s</sub> [kA]	dV/dT <sub>max</sub> [V/μs]	R <sub>THC</sub> natural cooling [°C/W]	Tan δ <sub>MAX</sub> @50Hz [10 <sup>-4</sup> ]	Ø [mm]	H [mm]	Weight [g]	Part. n. 416.42.	Pcs. / box	Box type
<b>Urms = 550 V</b>			<b>Un<sub>AC</sub> = 780 V</b>			<b>Un<sub>DC</sub> = 940 V</b>		<b>Us = 1680 V</b>				
1	7,0	11	0,1	60	6,3	3,0	30	98	70	4.10.x	125	6
2	7,0	11	0,1	60	5,2	3,0	30	98	80	4.15.x	125	6
5	8,5	13	0,3	60	4,5	3,5	40	98	140	4.33.x	50	7
10	9,5	14	0,7	60	3,5	4,0	50	98	220	4.58.x	25	7
15	10,0	15	0,7	40	2,4	4,5	55	132	360	4.63.x	25	6
20	10,0	15	0,9	40	2,4	4,5	55	132	370	4.68.x	25	6
25	10,0	15	1,1	40	2,1	5,0	60	137	420	4.78.x	25	6
35	10,0	15	1,0	25	1,7	5,5	60	181	560	4.88.x	18	6
<b>Urms = 690 V</b>			<b>Un<sub>AC</sub> = 990 V</b>			<b>Un<sub>DC</sub> = 1350 V</b>		<b>Us = 2240 V</b>				
0,68	7,0	11	0,1	60	6,3	3,0	30	98	80	6.12.x	125	6
1	7,0	11	0,1	60	6,3	3,0	30	98	90	6.15.x	125	6
2	8,0	12	0,1	60	5,2	3,0	35	98	110	6.23.x	50	7
5	9,5	14	0,3	60	3,5	4,0	50	98	220	6.51.x	25	7
8	10,0	15	0,4	40	2,4	4,5	55	132	360	6.62.x	25	6
10	10,0	15	0,4	40	2,4	4,5	55	132	370	6.68.x	25	6
12	10,0	15	0,7	40	2,1	5,0	60	137	420	6.74.x	25	6
20	10,0	15	0,6	25	1,7	5,5	60	181	560	6.88.x	18	6
<b>Urms = 930 V</b>			<b>Un<sub>AC</sub> = 1300V</b>			<b>Un<sub>DC</sub> = 1700 V</b>		<b>Us = 2800 V</b>				
0,68	8,5	13	0,1	60	3,9	3,0	40	115	160	9.10.4	50	7
1	8,5	13	0,1	60	3,9	3,0	40	115	170	9.14.4	50	7
2	8,5	13	0,1	60	3,9	3,0	40	115	190	9.18.4	50	7
5	10,5	16	0,3	60	2,7	4,0	55	115	300	9.49.4	25	6
8	12,0	18	0,4	40	2,0	4,5	60	150	470	9.61.4	25	6
10	14,0	21	0,4	40	1,8	5,0	65	150	550	9.75.4	20	6
12	16,0	24	0,5	35	1,7	5,5	65	165	600	9.85.4	15	6
14	16,0	24	0,5	35	1,7	5,5	65	165	620	9.89.4	15	6

(Cn) Standard values, other values on request.

Code "x": according to the mechanical configuration, see figures at page 17 (only for A solution).

Box TYPE	Standard box dimensions
6	mm 195 x 390 x 250
7	mm 195 x 390 x 200

STUD	Capacitor diameter
M8	Ø 25 - 30 - 40 - 45 - 50
M12	Ø 55 - 60

# Power Electronics Capacitors

## GENERAL PURPOSE CAPACITORS

### GP 42 Series

#### Mechanical Solutions

**A solution**  
 $U_{rms} \leq 690V$

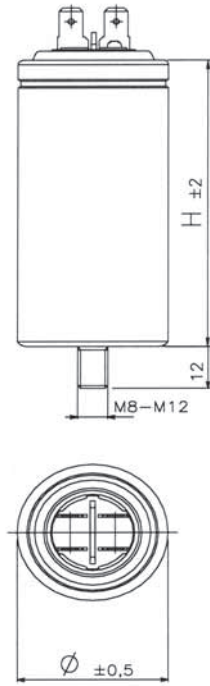

X = according to table 1

**B solution**  
 $U_{rms} = 930V$

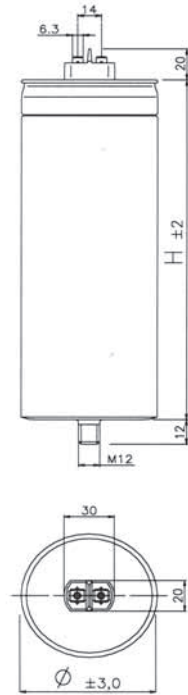

X = 4

#### Over pressure safety device

**A solution**  
**Overpressure safety device**

*In order to ensure proper device operation, when the capacitor is installed, a clearance of at least 10mm must be left above terminals.*

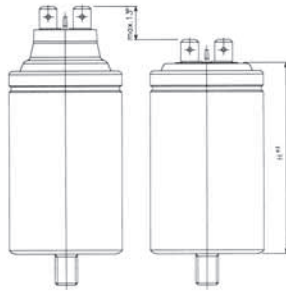

**B solution**  
**Overpressure safety device**

*In order to ensure proper device operation, when the capacitor is installed, a clearance of at least 20mm must be left above terminals.*

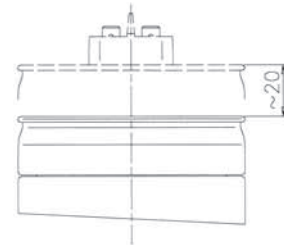

#### Plastic cover configurations - only for A solutions

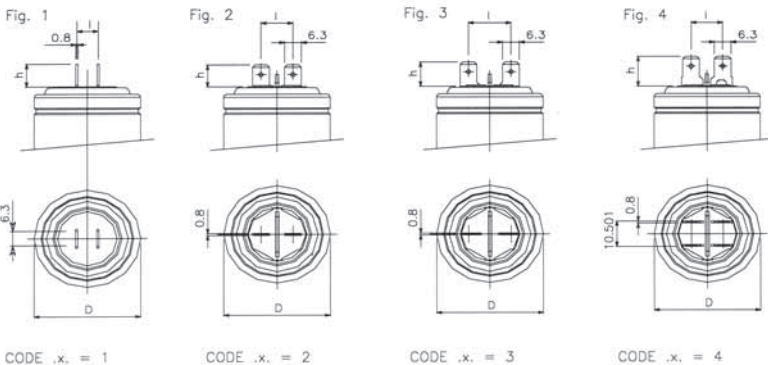

**Table 1**

øD Cap.	Fig.1		Fig.2		Fig.3		Fig.4	
	h (mm)	l (mm)	h (mm)	l (mm)	h (mm)	l (mm)	h (mm)	l (mm)
25	10.9	8						
30			9	12				
35			9	12			12.2	12
40			9	12	10	16	12.2	12
45			9	12	10	16	12.2	12
50			9	12	10	16	12.2	12
55			9	12	10	16	12.2	12
60			8.9	15.5			12	20.5

# Power Electronics Capacitors

## GENERAL PURPOSE CAPACITORS



### GP 84 Series

RMS Voltage range	250÷1000V
Capacitance range	10÷600 $\mu$ F
Capacitance tolerance	$\pm$ 5% / $\pm$ 10%
Max. RMS current	80 A
Series resistance ( $R_s$ )	< 8 m $\Omega$
Thermal resistance natural cooling ( $R_{THc}$ )	< 3,0 $^{\circ}$ C/W
Max. voltage raise of rise (dV/dT)	$\leq$ 100 V/ $\mu$ s
Terminals	M6 or M10 screw-type bolts or double tag 6,3 x 0,8 mm
Working temperature	-40 / + 70 $^{\circ}$ C
Storage temperature	-40 / + 85 $^{\circ}$ C
Test voltage	$U_{tc}$ = 3 kVac / 6 kVac @50 Hz 10s $U_{tt}$ = 1,5 x $U_{NDC}$ 10s
Filling	Dry polyurethane resin
Dielectric	Metallized PPMh film
Cylindrical case	Aluminum
Life expectancy	100.000 h (*)
Failure quota	50/10E9
Reference standard	IEC 1071-1/2; UL 810
UL-CSA approved (c  us) -10 kA AFC	File n. E102953 (**)
Integrated overpressure protection	
M6 Screw Terminals	3 Nm
M10 Screw Terminals	6 Nm(***)
M12 fixing bolt	Max 10 Nm

(\*) Life Derating at operating voltage (according to the chart on page 10)

Life expectancy	4.16.84.2xxx Series	4.16.84.3xxx Series	4.16.84.4xxx Series	4.16.84.5xxx Series	4.16.84.6xxx Series	4.16.84.9xxx Series
100.000 h (rated)	250 V	330 V	450 V	550 V	690 V	930 V
50.000 h	275 V	360 V	500 V	575 V	760 V	1025 V
25.000 h	300 V	400 V	540 V	630 V	830 V	1120 V
12.500 h	330 V	450 V	600 V	690 V	930 V	1250 V

(\*\*) UL Approved for A, C and F solution (excepted series 690 V - 930 V solution A).

(\*\*\*) To avoid breaking, complete the tightening of the nuts using two wrenches.



# Power Electronics Capacitors

## GENERAL PURPOSE CAPACITORS

### GP 84 Series

Cn [μF]	I <sub>MAX</sub> * [A]	I <sub>PK</sub> C <sub>W</sub> [A]	I <sub>PK</sub> I <sub>W</sub> [kA]	I <sub>s</sub> [kA]	R <sub>THC</sub> [°C/W]	L <sub>ESR</sub> [nH]	Tan δ <sub>MAX</sub> @50Hz [10 <sup>-4</sup> ]	Ø [mm]	H [mm]	Weight [g]	Mechanical solution	Part. n. 416.84.	Pcs. / box	Box type
<b>Urms = 250 V</b>				<b>Un<sub>AC</sub> = 350 V</b>				<b>Un<sub>DC</sub> = 490 V</b>		<b>Us = 950 V</b>				
60	22	33	1,7	9	2,7	130	5,0	55	115	300	A / C	2.1x.y	28	1
80	22	33	1,7	9	2,7	130	5,0	55	115	340	A / C	2.1x.y	28	1
100	25	38	1,9	11	2,2	160	5,0	55	150	370	A / C	2.2x.y	21	1
120	25	38	1,9	11	2,2	160	5,0	55	150	390	A / C	2.2x.y	21	1
150	32	48	2,4	13	2,0	160	5,5	60	150	450	A / C	2.3x.y	18	1
175	36	54	2,7	16	1,8	170	6,0	65	150	520	A / C	2.4x.y	16	1
200	38	57	2,9	12	1,7	180	6,5	65	165	580	A / C	2.5x.y	16	1
230	40	60	3,0	20	1,3	200	7,0	75	180	820	F	2.6x.7	6	2
250	40	60	3,0	20	1,3	200	7,0	75	180	830	F	2.6x.7	6	2
300	40	60	3,0	20	1,3	200	7,0	75	180	860	F	2.6x.7	6	2
350	45	68	3,4	20	1,1	210	7,5	85	180	980	F	2.7x.7	6	2
400	45	68	3,4	20	1,1	210	7,5	85	180	1050	F	2.7x.7	6	2
500	78	117	5,9	20	0,9	230	8,5	90	210	1400	F	2.9x.7	6	3
600	80	120	6,0	18	0,8	300	9,0	85	280	1700	F	2.9x.7	6	4
<b>Urms = 330 V</b>				<b>Un<sub>AC</sub> = 470 V</b>				<b>Un<sub>DC</sub> = 600 V</b>		<b>Us = 1150 V</b>				
50	22	33	1,7	7	2,7	160	5,0	55	115	320	A / C	3.1x.y	28	1
80	26	39	2,0	8	2,2	160	6,0	55	150	390	A / C	3.2x.y	21	1
100	26	39	2,0	8	2,2	160	6,0	55	150	400	A / C	3.2x.y	21	1
120	30	45	2,3	10	2,0	160	6,0	60	150	460	A / C	3.3x.y	18	1
150	34	51	2,6	13	1,8	170	6,5	65	50	540	A / C	3.4x.y	16	1
175	38	57	2,9	10	1,7	180	7,0	65	165	600	A / C	3.5x.y	16	1
200	40	60	3,0	14	1,3	200	7,5	75	180	860	F	3.6x.7	6	2
250	40	60	3,0	14	1,3	200	7,5	75	180	860	F	3.6x.7	6	2
300	45	68	3,4	18	1,1	210	7,5	85	180	1100	F	3.7x.7	6	2
350	70	105	5,3	16	1,0	230	8,0	85	210	1350	F	3.8x.7	6	3
400	75	113	5,6	18	0,9	230	8,5	90	210	1450	F	3.9x.7	6	3
450	80	120	6,0	13	0,8	300	9,0	85	280	1750	F	3.9x.7	6	4
<b>Urms = 450 V</b>				<b>Un<sub>AC</sub> = 630 V</b>				<b>Un<sub>DC</sub> = 825 V</b>		<b>Us = 1600 V</b>				
20	20	30	1,5	4	2,7	130	5,0	55	115	250	A / C	4.0x.y	28	1
30	20	30	1,5	4	2,7	130	5,0	55	115	300	A / C	4.0x.y	28	1
40	24	36	1,8	4,5	2,2	160	6,0	55	150	370	A / C	4.1x.y	21	1
50	24	36	1,8	4,5	2,2	160	6,0	55	150	400	A / C	4.1x.y	21	1
70	28	42	2,1	6,8	1,8	170	6,5	65	150	530	A / C	4.3x.y	16	1
80	28	42	2,1	6,8	1,8	170	6,5	65	150	550	A / C	4.3x.y	16	1
90	32	48	2,4	5,2	1,7	180	7,0	65	165	590	A / C	4.4x.y	16	1
100	38	57	2,9	7,4	1,3	200	7,5	75	180	860	F	4.5x.7	6	2
150	42	63	3,2	9,9	1,1	210	8,0	85	180	1100	F	4.6x.7	6	2
200	70	105	5,3	9,7	0,9	230	8,5	90	210	1450	F	4.8x.7	6	3
250	75	113	5,6	7,9	0,8	300	9,0	85	280	1710	F	4.9x.7	6	4
300	78	117	5,9	9,1	0,7	300	9,0	90	280	1920	F	4.9x.7	6	4

# Power Electronics Capacitors

## GENERAL PURPOSE CAPACITORS

### GP 84 Series

Cn [μF]	I <sub>MAX</sub> * [A]	I <sub>PK C<sub>W</sub></sub> [A]	I <sub>PK I<sub>w</sub></sub> [kA]	I <sub>s</sub> [kA]	R <sub>THC</sub> [°C/W]	L <sub>ESR</sub> [nH]	Tan δ <sub>MAX</sub> @50Hz [10 <sup>-4</sup> ]	Ø [mm]	H [mm]	Weight [g]	Technical solution	Part. n. 416.84.	Pcs. / box	Box type
<b>Urms = 550 V</b>				<b>Un<sub>AC</sub> = 790 V</b>				<b>Un<sub>DC</sub> = 940 V</b>		<b>Us = 1800 V</b>				
20	18	27	1,4	2,9	2,7	130	5,0	55	115	300	A / C	5.0x.y	28	1
30	20	30	1,5	3,3	2,2	160	5,5	55	150	350	A / C	5.1x.y	21	1
40	20	30	1,5	3,3	2,2	160	5,5	55	150	390	A / C	5.1x.y	21	1
50	22	33	1,7	4,1	2,0	160	6,0	60	150	460	A / C	5.2x.y	18	1
70	26	39	2,0	3,9	1,7	180	7,0	65	165	590	A / C	5.4x.y	16	1
80	34	51	2,6	5,3	1,3	200	7,5	75	180	820	F	5.5x.7	6	2
100	38	57	2,9	7,2	1,1	210	8,0	85	180	950	F	5.6x.7	6	2
125	38	57	2,9	7,2	1,1	210	8,0	85	180	1050	F	5.6x.7	6	2
150	70	105	5,3	5,7	0,8	300	8,5	85	280	1550	F	5.8x.7	6	4
200	70	105	5,3	5,7	0,8	300	8,5	85	280	1700	F	5.8x.7	6	4
250	76	114	5,7	8,3	0,6	320	9,0	100	280	2100	F	5.9x.7	6	5
300	76	114	5,7	8,3	0,6	320	9,0	100	280	2400	F	5.9x.7	6	5
<b>Urms = 690 V</b>				<b>Un<sub>AC</sub> = 990 V</b>				<b>Un<sub>DC</sub> = 1350 V</b>		<b>Us = 2600 V</b>				
10	20	30	1,0	1,8	2,2	160	5,0	55	150	310	A / C	6.0x.y	21	1
15	20	30	1,0	1,8	2,2	160	5,0	55	150	350	A / C	6.0x.y	21	1
20	22	33	1,1	2,8	1,8	170	5,0	65	150	500	A / C	6.1x.y	16	1
30	26	39	1,3	2,9	1,7	180	5,0	65	165	560	A / C	6.2x.y	16	1
40	30	45	1,5	4,0	1,3	200	5,5	75	180	780	F	6.3x.7	6	2
50	30	45	1,5	4,0	1,3	200	5,5	75	180	850	F	6.3x.7	6	2
70	34	51	1,7	4,9	1,0	210	6,0	85	210	1150	F	6.5x.7	6	3
85	36	54	1,8	5,5	0,9	220	6,5	90	210	1400	F	6.6x.7	6	3
100	38	57	1,9	7,1	0,8	220	7,0	100	210	1680	F	6.7x.7	6	5
125	40	60	2,0	4,2	0,7	300	7,5	90	280	1860	F	6.8x.7	6	4
150	45	68	2,3	5,3	0,6	300	8,0	100	280	2150	F	6.9x.7	6	5
175	45	68	2,3	5,3	0,6	300	8,0	100	280	2360	F	6.9x.7	6	5
<b>Urms = 930 V</b>				<b>Un<sub>AC</sub> = 1300 V</b>				<b>Un<sub>DC</sub> = 1700 V</b>		<b>Us = 3250 V</b>				
10	18	27	0,9	1,2	2,2	160	4,5	55	150	360	A / C	9.0x.y	21	1
15	20	30	1,0	1,8	1,8	170	4,7	65	150	480	A / C	9.1x.y	16	1
20	22	33	1,1	1,8	1,7	180	5,0	65	165	550	A / C	9.2x.y	16	1
30	24	36	1,2	2,6	1,3	200	5,3	75	180	840	F	9.3x.7	6	2
35	28	42	1,4	2,3	1,1	210	5,5	75	210	980	F	9.4x.7	6	3
40	30	45	1,5	3,1	1,0	210	5,5	85	210	1150	F	9.5x.7	6	3
45	30	45	1,5	3,1	1,0	210	5,5	85	210	1220	F	9.5x.7	6	3
50	30	45	1,5	3,1	1,0	210	5,5	85	210	1280	F	9.5x.7	6	3
55	34	51	1,7	3,5	0,9	220	5,7	90	210	1380	F	9.6x.7	6	3
70	38	57	1,9	4,5	0,8	220	5,7	100	210	1720	F	9.7x.7	6	5
85	42	63	2,1	2,7	0,7	300	6,0	90	280	1840	F	9.8x.7	6	4
100	45	68	2,3	3,4	0,6	300	6,5	100	280	2250	F	9.9x.7	6	5

(Cn) Standard values, other values on request.

Code "x": internal reference. Code "y": mechanical solution.

(\*) The maximum rms current is referred to A or F solutions. I<sub>max</sub> ≤ 16 A for C solution.

Box TYPE	Standard box dimensions
1	mm 250 x 386 x 190
2	mm 190 x 285 x 265
3	mm 190 x 285 x 325
4	mm 190 x 285 x 375
5	mm 335 x 220 x 375

# Power Electronics Capacitors

## GENERAL PURPOSE CAPACITORS

### GP 84 Series

General technical information:  
maximum current ( $I_{max}$ ) versus temperature.

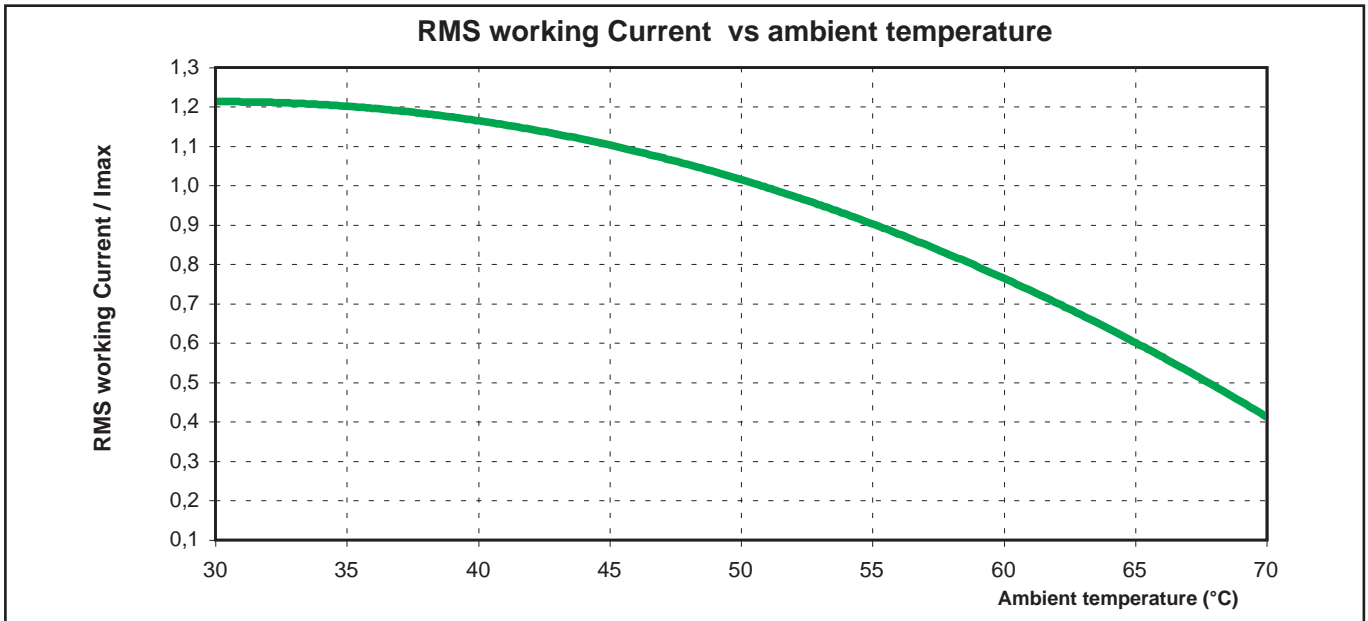

#### Mechanical Configurations:

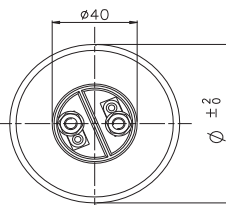
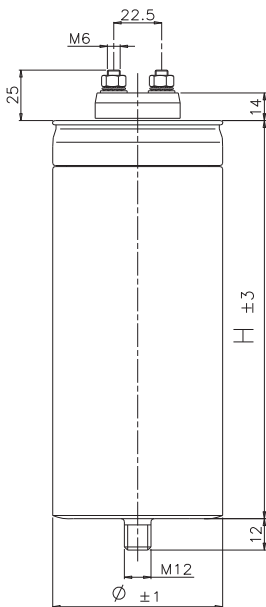

**A solution**  
M6 Screw-type bolts  
CODE: 41684.xxx.0  
Code "y"=0

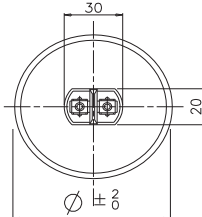
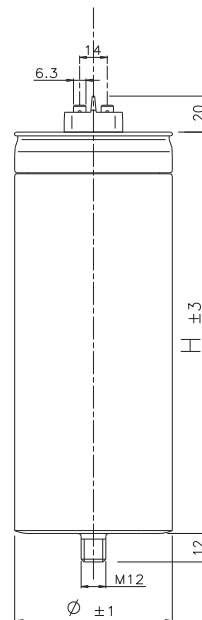

**C solution**  
Double tag 6,3x0,8 mm  
CODE: 41684.xxx.2  
Code "y"=2

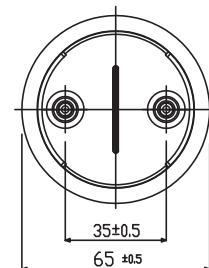
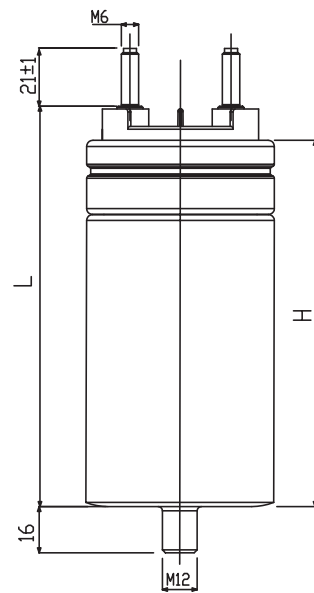

**D solution (\*)**  
M6 crew-type bolts / plastic top  
CODE: 41684.xxx.6  
Code "y"=6

(\*) For Ø=65mm, on request also for other different diameter.

# Power Electronics Capacitors

## GENERAL PURPOSE CAPACITORS

### GP 84 Series

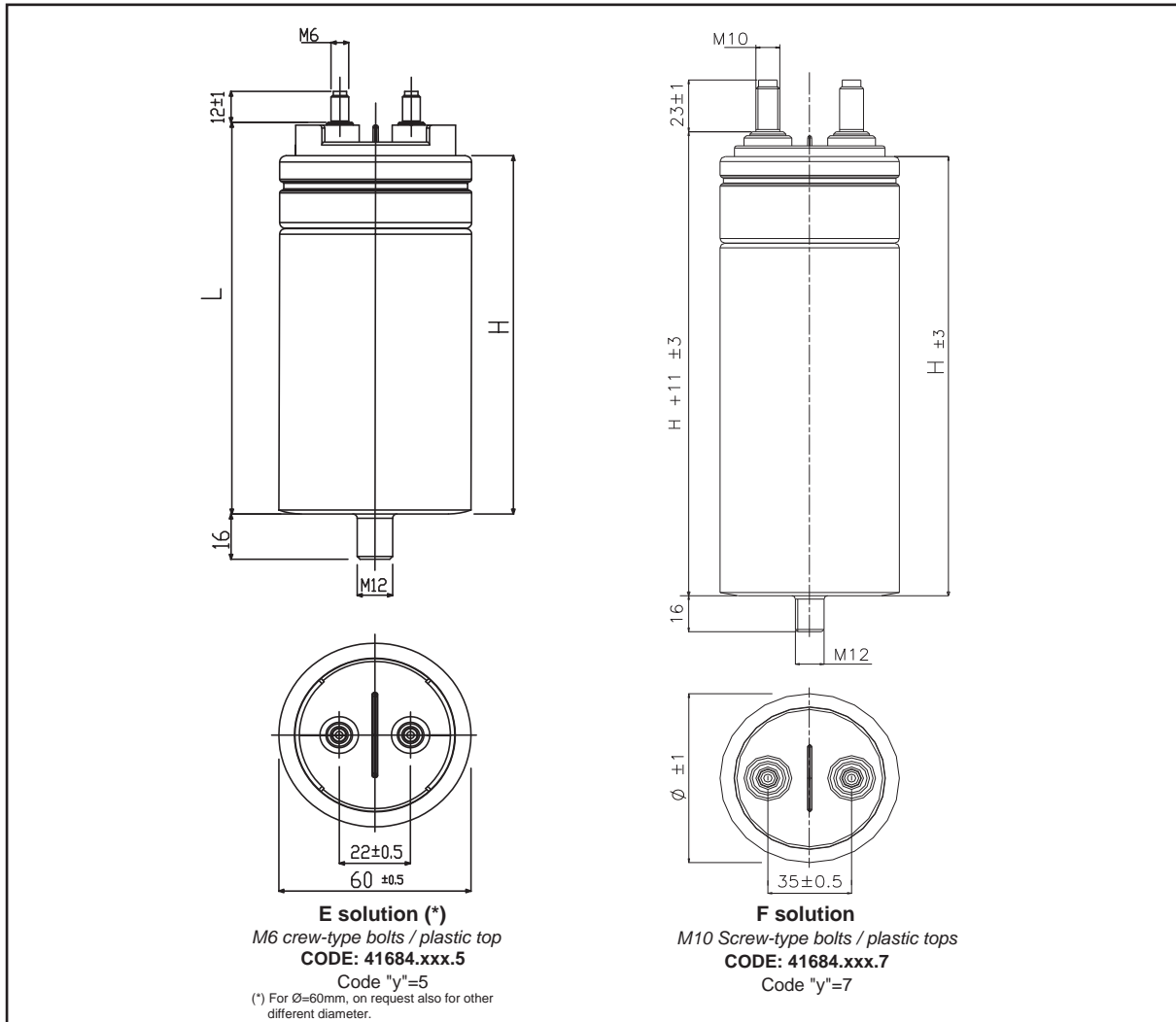

### Overpressure safety device

In order to ensure proper device operation, when the capacitor is installed, a clearance of at least the values given on drawing below must be left above terminals.

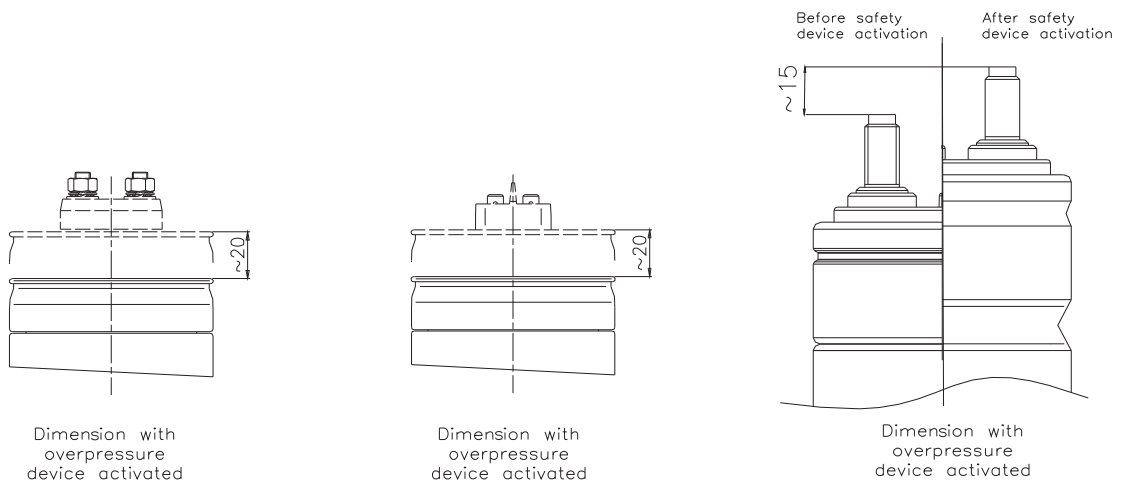



# Power Electronics Capacitors

## DC CAPACITORS

### DC SERIES - DC-link capacitor

Capacitors for power inverter in railway, welding and special applications by energy storage and filtering.

#### FEATURES

- Plastic, steel and aluminum case/can
- Dry type
- Internal thread, screw type bolts or tinned wires for PCB mounting
- DC voltage

#### TYPICAL APPLICATIONS

- Traction and railway filtering
- DC filtering / snubber filtering
- Welding
- Special inverter
- UPS system



<i>GENERAL CHARACTERISTICS</i>	
DC Voltage range	DC 500÷6800 V (*)
Capacitance range	1÷15000 µF (*)
Capacitance tolerance	±10% ; ±5% ; +0% / -15%
Test voltage between terminals	1,5 x Un 10s
Test voltage between terminals and case	3 KVac 50 Hz - 10s
Operating Temperature	-25 / +75 °C
Protection degree	IP 00
Filling	Self-extinguishing (V0) polyurethane resin
Dielectric	Self healing MKP dielectric with high performances (PPMd)
Case	Cylindrical aluminum case, self-extinguishing (V0) plastic box or stainless steel case
Life expectancy	100.000 h
Installation	Vertical / horizontal
Reference standard	Standards IEC 1071-1/2; IEC 1881; UL 810
UL - CSA approved (UL US)	File n. 192559

(\*) Standard values, other values on request.

## NEW DCH High-Density / Temperature Series Up to 30% more density compared to standard ranges!

DCH Series Capacitors are equipped with the new PPMdH High-Performance Film developed by Ducati Energia, which guarantees high capacity densities and high operating temperatures.

- **DCH85C – Cylindrical, High-Density, Low-Induction DC-Link Capacitor**  
60÷5600µF – 700÷2100Vdc, Page 27÷31



- **DCH86PS – Boxed, High-Density, Very Low-Induction DC-Link Capacitor**  
230÷2100µF -700÷2500Vdc, Page 32÷34



The New, DC-specific Metallized PPMdH Polypropylene Film is the result of Ducati Energia efforts to increase dielectric strength and temperature behavior respective to traditional Metallized Polypropylene Films. Respective to traditional Polypropylene Films, PPMdH provides

- **Increased Dielectric Strength: +25%**

The increased Dielectric Strength allows the use of thinner Polypropylene Films for the same Voltage Rating; the result is a higher Capacity [µF] / Volume [cm<sup>3</sup>] density as detailed in the product pages for DCH85C (pp 27÷31) and DCH86PS (pp 32÷34) and summarized in the diagram.

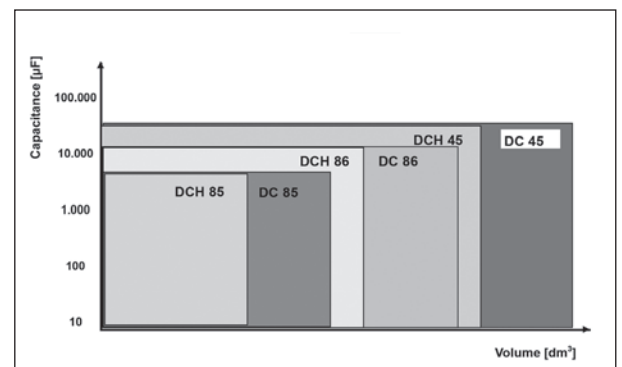

- **Increased Operating Temperature (HotSpot): +20°C**

The special metallization and higher crystallinity of the polypropylene increase the critical temperature for the film and decrease its ageing rate when used at high temperatures. Conventional Polypropylene Films reach maximum 100.000hrs of operation at 70°C HotSpot, whereas PPMdH reaches the same 100.000hrs at 90°C HotSpot.

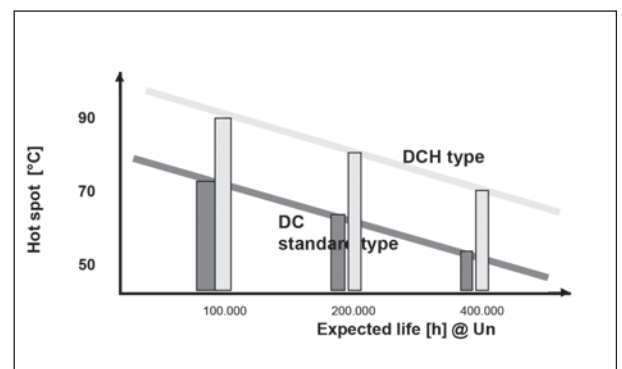

### High Temperature Use:

The DCH85C and DCH86PS product pages in this catalogue express the high capacity density application of the new PPMdH film; for the high-temperature application of the new PPMdH film, we kindly invite you to contact Ducati Energia.



**DC CAPACITORS**



**DCH 85 C SERIES:**  
***Dc - Link Capacitors / high density serie and low inductance in cylindrical can***

DC Voltage range	700÷2100 V
Maximum ripple voltage	1150 V
Maximum ripple current	100 A
Capacitance range	Up to 5600 $\mu$ F
Capacitance tolerance	$\pm$ 10% or $\pm$ 5%
Series resistance (Rs)	< 4,5 m $\Omega$
Maximum Voltage rate of rise (dV/dT)	$\leq$ 40 V/ $\mu$ s
Terminals	M6 internal threads M8 screw types bolts
Voltage test	U <sub>tc</sub> = 3,5 kVac @50Hz 10s U <sub>tt</sub> = 1,5 x U <sub>nDC</sub> 10s
Climatic Ambient Temperature	-25 / +45 °C
Working temperature ( $\theta_{MIN}$ – $\theta_{MAX}$ )	-25 / +85 °C
Storage temperature	-25 / +85 °C
Filling	Dry polyurethane resin
New PP Dielectric	Self healing. PPMdh film
Cylindrical case	Aluminum
Failure quota	50/10E9
Life expectancy	100.000 h
Maximum altitude	2000 m a.s.l.
Reference standard	IEC 1071-1/2 IEC 1881 UL 810
Internal thread terminals	Max 3 Nm
M8 screw terminals	Max 6 Nm
M12 fixing bolt	Max 12 Nm
UL - CSA approved (c  )	File n. E192559

**Safety system:** These capacitors are designed with a particular type of polypropylene metalized film (PPMd film) that assures an open circuit at the end of life, if the operation is within the specification.

# Power Electronics Capacitors

## DC CAPACITORS

### DCH 85 C SERIES

Capacitance Cn [uF]	Diameter Ø [mm]	Height H [mm]	Max. RMS Current I <sub>MAX</sub> [A]	Repet. Peak Current Ip [A]	Surge Current Is [kA]	Series Resistance Rs [mΩ]	Thermal Resistance R <sub>THC</sub> [°C/W]	Series Inductance Lesr [nH]	Weight [Kg]	Pcs. / Box Box type	Part number 416.85.V.
<b>UnDC = 700 V</b>			<b>Ur = 320 V</b>			<b>Up = 1050 V</b>			<b>Us = 1470V</b>		
480	75	105	25	1500	5,0	3,8	5,4	< 45	0,6	12 - A	009.x
750	75	140	30	2200	6,5	3,6	4,8	< 50	0,8	6 - B	019.x
840	75	155	35	2200	7,0	3,0	4,6	< 60	0,9	6 - B	029.x
980	85	140	35	3000	7,5	2,9	4,2	< 50	1,0	6 - B	039.x
1.050	90	140	40	3000	8,0	2,8	4,0	< 50	1,1	6 - B	045.x
1.100	85	155	40	3000	9,0	2,7	3,6	< 60	1,1	6 - B	049.x
1.800	100	185	65	3700	11,0	1,6	2,6	< 60	1,8	6 - C	055.x
2.500	116	185	70	4000	12,0	1,4	2,3	< 60	2,3	4 - G	059.X
2.700	100	255	70	4200	13,0	1,2	2,3	< 75	2,4	6 - D	069.x
3.700	116	255	75	5800	15,0	1,0	2,1	< 75	3,2	4 - G	079.x
4.300	116	285	80	6700	18,0	0,8	1,7	< 80	3,6	4 - G	089.x
5.600	116	373	100	10000	22,0	0,7	1,6	< 90	4,8	4 - G	095.x
<b>UnDC = 900 V</b>			<b>Ur = 550 V</b>			<b>Up = 1350 V</b>			<b>Us = 1900V</b>		
340	75	105	28	2200	6,6	3,9	5,4	< 45	0,6	12 - A	109.x
500	75	140	30	2800	8,4	3,7	4,8	< 50	0,8	6 - B	119.x
600	75	155	35	3200	9,6	3,2	4,6	< 60	0,9	6 - B	129.x
680	85	140	35	3300	10,0	3,1	4,2	< 50	1,0	6 - B	135.x
780	90	140	40	3500	10,0	3,0	4,0	< 50	1,1	6 - B	139.x
800	85	155	40	3800	11,5	2,9	3,6	< 60	1,1	6 - B	149.x
1.300	100	185	65	5400	16,0	1,8	2,6	< 60	1,8	6 - C	155.x
1.850	116	185	70	6600	20,0	1,7	2,3	< 60	2,3	4 - G	159.x
2.000	100	255	70	7000	21,0	1,6	2,3	< 75	2,4	6 - D	169.x
2.700	116	255	75	7100	21,0	1,3	2,1	< 75	3,2	4 - G	179.x
3.200	116	285	85	8200	24,5	1,2	1,7	< 80	3,5	4 - G	189.x
4.500	116	373	100	10000	28,0	1,0	1,6	< 90	4,6	4 - G	195.x
<b>UnDC = 1100 V</b>			<b>Ur = 700 V</b>			<b>Up = 1650 V</b>			<b>Us = 2300V</b>		
260	75	105	30	2200	6,7	4,1	5,4	< 45	0,7	12 - A	219.x
400	75	140	35	2400	7,1	3,8	4,8	< 50	0,8	6 - B	239.x
520	85	140	35	3400	10,3	3,6	4,2	< 50	1,0	6 - B	249.x
600	90	140	40	3600	10,3	3,5	4,0	< 50	1,1	6 - B	259.x
680	90	155	40	3900	11,7	3,5	3,6	< 60	1,3	6 - B	269.x
1.000	100	185	65	5300	15,8	2,2	2,6	< 70	1,8	6 - C	279.x
1.400	116	185	70	7300	21,8	2,0	2,3	< 70	2,3	4 - G	285.x
1.500	100	255	70	7800	23,3	1,9	2,3	< 75	2,4	6 - D	289.x
1.750	100	285	75	8100	24,3	1,8	2,2	< 80	2,6	6 - E	291.x
2.100	116	255	75	9900	29,7	1,4	2,1	< 75	3,2	4 - G	293.x
2.300	100	373	100	10500	31,7	1,2	1,8	< 90	3,5	6 - F	295.x
2.400	116	285	85	10000	30,0	1,5	1,7	< 80	3,6	4 - G	297.x
3.200	116	373	100	11550	30,0	1,1	1,6	< 90	4,7	4 - H	299.x
<b>UnDC = 1350 V</b>			<b>Ur = 850 V</b>			<b>Up = 2000 V</b>			<b>Us = 2800V</b>		
170	75	105	30	2160	6,5	4,2	5,4	< 45	0,6	12 - A	319.X
250	75	140	35	3240	9,7	3,9	4,8	< 50	0,8	6 - B	329.X
340	85	140	35	3960	11,9	3,7	4,2	< 50	1,0	6 - B	339.X
380	85	155	40	4200	12,6	3,6	3,6	< 60	1,1	6 - B	350.X
500	90	185	65	5200	16,0	3,1	2,8	< 70	1,5	6 - C	355.X
640	100	185	65	5850	17,6	2,3	2,6	< 70	1,8	6 - C	360.X
880	116	185	70	8100	24,3	2,1	2,3	< 70	2,4	4 - G	365.X
960	100	255	70	8500	25,5	2,0	2,3	< 75	2,4	6 - D	370.X
1.100	100	285	75	9200	27,6	1,9	2,2	< 80	2,6	6 - E	380.X
1.350	116	255	75	11900	30,0	1,7	2,1	< 75	3,2	4 - G	385.X
1.450	100	373	100	13500	32,0	1,3	1,8	< 90	3,5	6 - F	389.X
1.550	116	285	85	12800	32,0	1,7	1,7	< 80	3,5	4 - G	393.X
2.000	116	373	100	14400	32,0	1,3	1,6	< 90	4,4	4 - H	398.X

# Power Electronics Capacitors

## DC CAPACITORS

### DCH 85 C SERIES

Capacitance Cn [uF]	Diameter Ø [mm]	Height H [mm]	Max. RMS Current I <sub>MAX</sub> [A]	Repet. Peak Current Ip [A]	Surge Current Is [kA]	Series Resistance Rs [mΩ]	Thermal Resistance R <sub>THC</sub> [°C/W]	Series Inductance Lesr [nH]	Weight [Kg]	Pcs. / Box - Box type	Part number 416.85.V.
<b>UnDC = 1600 V</b>			<b>Ur = 990 V</b>			<b>Up = 2400 V</b>			<b>Us = 3100V</b>		
120	75	105	30	2160	6,5	4,3	5,4	< 45	0,6	12 - A	419.x
180	75	140	35	3240	9,7	4,0	4,8	< 50	0,8	6 - B	420.x
230	85	140	35	4000	12,0	3,9	4,2	< 50	1,0	6 - B	430.x
260	85	155	40	4200	12,0	3,8	4,0	< 50	1,2	6 - B	435.x
350	90	185	40	4480	13,5	3,7	3,6	< 60	1,5	6 - B	440.x
450	100	185	65	7200	21,6	2,3	2,6	< 70	1,8	6 - C	450.x
530	90	255	70	8500	25,0	2,2	2,4	< 70	2,3	6-D	453.x
620	116	185	70	9750	29,5	2,2	2,3	< 70	2,4	4 - G	455.x
680	100	255	70	9800	30,0	2,1	2,3	< 75	2,5	6 - D	460.x
780	100	285	75	11200	32,0	2,0	2,2	< 80	2,7	6 - E	470.x
930	116	255	75	12740	32,0	1,8	2,1	< 75	3,2	4 - G	475.x
1.000	100	373	100	12600	32,0	1,3	1,8	< 90	3,5	6 - F	485.x
1.100	116	285	85	13800	32,0	1,8	1,7	< 80	3,6	4 - G	489.x
1.400	116	373	100	14500	32,0	1,4	1,6	< 90	4,7	4 - H	495.x
<b>UnDC = 1900 V</b>			<b>Ur = 1150 V</b>			<b>Up = 2700 V</b>			<b>Us = 3100V</b>		
85	75	105	30	2250	6,5	4,4	5,4	< 45	0,6	12 - A	519.x
130	75	140	35	2940	9,7	4,1	4,8	< 50	0,8	6 - B	520.x
170	85	140	35	3600	12,0	4,0	4,2	< 50	1,0	6 - B	530.x
200	85	155	40	4200	13,5	3,8	3,6	< 60	1,1	6 - B	540.x
230	90	155	45	5000	15,0	3,4	3,3	< 60	1,2	6 - B	545.x
330	100	185	65	7000	21,6	2,3	2,6	< 70	1,9	6 - C	550.x
380	90	255	70	7500	25,0	2,2	2,4	< 70	2,1	6 - D	557.x
450	116	185	70	8460	29,5	2,3	2,3	< 70	2,4	4 - G	555.x
500	100	255	70	9000	30,0	2,2	2,3	< 75	2,4	6 - D	560.x
570	100	285	75	9600	32,0	2,0	2,2	< 80	2,6	6 - E	570.x
680	116	255	75	11200	32,0	1,9	2,1	< 75	3,2	4 - G	575.x
740	100	373	100	12000	32,0	1,4	1,8	< 90	3,3	6 - F	580.x
780	116	285	85	13120	32,0	1,9	1,7	< 80	3,6	4 - G	585.x
1.030	116	373	100	14700	32,0	1,4	1,6	< 90	4,6	4 - H	598.x
<b>UnDC = 2100V</b>			<b>Ur = 1150 V</b>			<b>Up = 2700 V</b>			<b>Us = 3100V</b>		
60	75	105	30	2100	6,5	4,5	5,4	< 45	0,6	12 - A	610.x
90	75	140	35	3000	9,7	4,2	4,8	< 50	0,8	6 - B	620.x
125	85	140	35	3375	12,0	4,1	4,2	< 50	1,0	6 - B	630.x
145	85	155	40	3450	13,5	3,9	3,6	< 60	1,1	6 - B	640.x
160	90	155	45	3900	15,0	3,4	3,3	< 60	1,3	6 - B	645.x
210	100	185	65	4800	21,6	2,3	2,6	< 70	1,5	6 - C	650.x
290	90	255	70	6500	25,0	2,1	2,4	< 70	2,2	6 - D	653.x
320	116	185	70	6800	29,5	2,2	2,3	< 70	2,4	4 - G	655.x
360	100	255	70	7400	30,0	2,1	2,3	< 75	2,3	6 - D	660.x
420	100	285	75	9600	32,0	2,0	2,2	< 80	2,7	6 - E	670.x
510	116	255	75	10750	32,0	2,0	2,1	< 75	3,3	4 - G	675.x
540	100	373	100	11500	32,0	1,4	1,8	< 90	3,5	6 - F	680.x
580	116	285	85	12500	32,0	1,9	1,7	< 80	3,6	4 - G	685.x
760	116	373	100	14400	32,0	1,5	1,6	< 90	4,7	4 - H	698.x

**NOTES:**

- (Cn) Tolerance standard value: ±10%. Other tolerance values on request.
- (Cn) - (Un) Capacitance and rated voltage standard values, other values on request.
- (Ur) Maximum peak to peak alternating voltage component on the DC working voltage
- (Rs) Releled at 1KHz.
- (R<sub>THC</sub>) Thermal resistance CASE TO AMBIENT in natural cooling enviroment.
- (Imax) Maximum RMS current, refered to an abient temperature of 50°C (natural cooling) and a working frequency of 1KHz.
- (x code) According to the terminal type: x = 0 --> A SOLUTION (internal thread M6) / x = 1 --> B SOLUTION (M8 screw type bolts).

### Mechanical standard configuration:

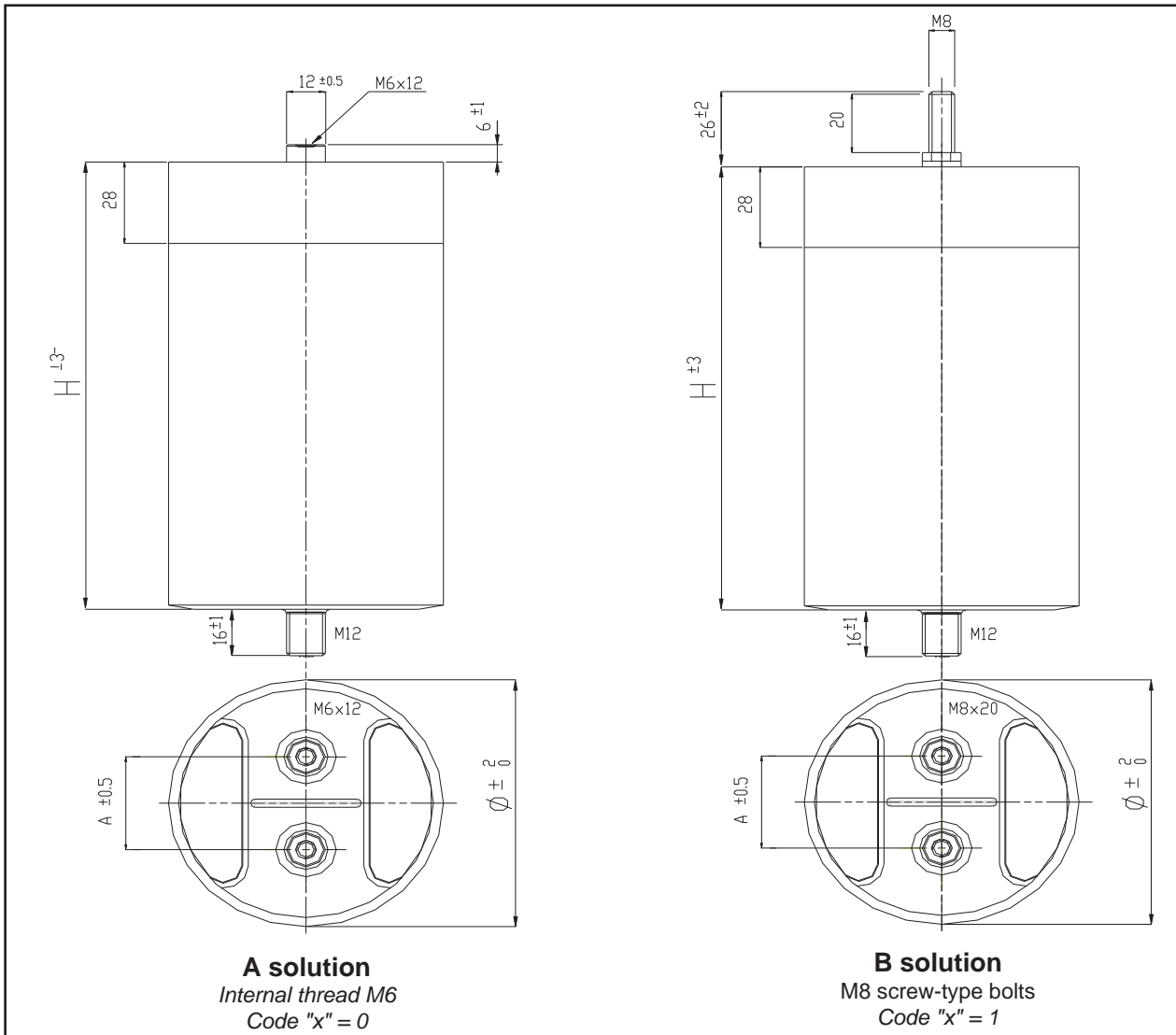

Diameter $\varnothing$ [mm]	A spacing [mm]	Type of terminal	Insulation spacing	
			Surface [mm]	Air [mm]
From 75 to 100	32	M6 female / M8 male	36	20
90	45 (*)	M6 female / M8 male	49	33
116	50	M6 female / M8 male	54	38

(\*) Available also in the dimension: 32 - 50 mm

### Terminal type on request:

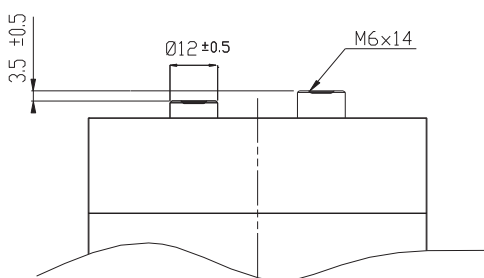

Two different terminals height for special BUS BAR coupling.

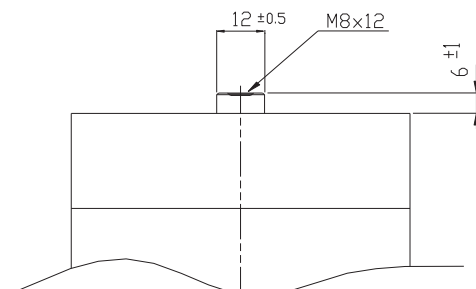

Available M8 internal thread on the same terminal dimension.

# DC CAPACITORS

## DCH 85 C Series

Box Type	Box Type Dimensions
A	mm 190 x 285 x 280
B	mm 190 x 285 x 200
C	mm 220 x 335 x 265
D	mm 220 x 335 x 325
E	mm 220 x 335 x 375
F	mm 220 x 335 x 450
G	mm 270 x 270 x 380
H	mm 270 x 270 x 450

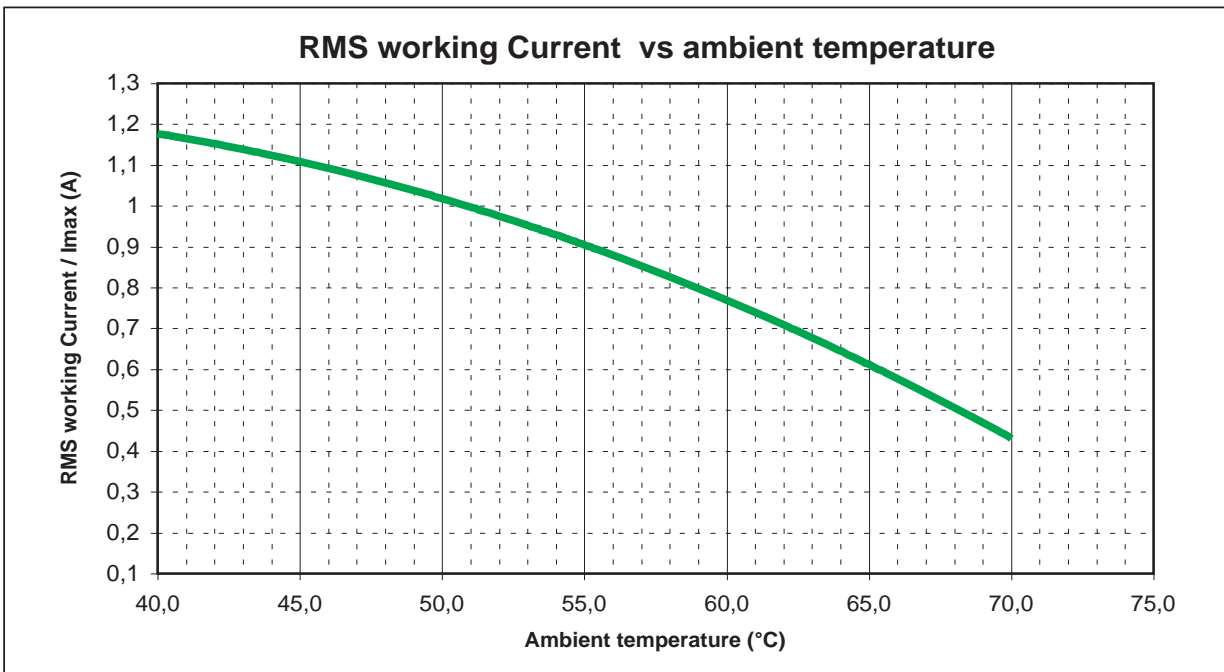

## Power Electronics Capacitors

### DC CAPACITORS



#### **DCH 86 PS SERIES: Dc - Link Capacitors / high density and low inductance serie in box case**

DC Voltage range	700÷2500 V
Maximum ripple current	165 A
Capacitance range	Up to 2100 $\mu$ F
Capacitance tolerance	$\pm 10\%$
Thermal resistance natural cooling ( $R_{THC}$ )	2.60 $^{\circ}$ C/W
Equivalent series inductance ( $L_{ESR}$ )	< 30 nH
Terminals	M8 x 15 internal threads
Test voltage	$U_{tc} = 4.5 \text{ kVac @ } 50 \text{ Hz } 60\text{s}$ $U_{tt} = 1.5 \times U_{nDC} 10\text{s}$
Climatic Ambient Temperature	-25 / +45 $^{\circ}$ C
Working temperature ( $\theta_{MIN} - \theta_{MAX}$ )	-25 / +85 $^{\circ}$ C
Storage temperature	-25 / +85 $^{\circ}$ C
Filling	Self-extinguishing (UL94 V0) polyurethane resin
New PP Dielectric	Self healing PPMdh film
Container	Self-extinguishing (UL94 V0) plastic box
Failure quota	50/10E9
Life expectancy	100.000 h
Maximum altitude	2000 m a.s.l.
Reference standard	IEC 1071-1/2 IEC 1881 UL 810
M8 internal thread terminals	Max 4 Nm
Fixing slots	Max 10 Nm
UL - CSA approved (c  )	File n. E192559

**Safety system:** These capacitors are designed with a particular type of polypropylene metalized film (PPMd film) that assures an open circuit at the end of life, if the operation is within the specification.



# Power Electronics Capacitors

## DC CAPACITORS

### DCH86 PS SERIES

Capacitance Cn [uF]	Rated DC Voltage Un [V]	Repet. Peak Voltage Up [KV]	Surge Voltage Us [KV]	Max. RMS Current I <sub>MAX</sub> [A]	Repet. Peak Current Ip [A]	Surge Current Is [kA]	Series Resistance Rs [mΩ]	Thermal Resistance R <sub>THS</sub> [°C/W]	Weight [kg]	Part number 416.86.V.xxxx
2.100	700	1,1	1,2	165	15.000	28,0	< 0,48	2,60	< 4,5	1095
1.500	850	1,0	1,5	155	13.800	26,0	< 0,50	2,60	< 4,5	1595
1.150	1100	1,7	2,3	150	12.000	25,0	< 0,55	2,60	< 4,5	2095
750	1250	1,9	2,625	140	11.400	23,0	< 0,59	2,60	< 4,5	2595
600	1400	2,1	2,9	130	11.000	21,5	< 0,66	2,60	< 4,5	3095
500	1600	2,4	3,36	120	10.640	20,5	< 0,73	2,60	< 4,5	3595
380	1800	2,7	3,8	120	10.500	19,0	< 0,85	2,60	< 4,5	4095
300	2100	3,2	4,5	110	9.660	18,5	< 0,89	2,60	< 4,5	4595
230	2500	3,8	4,5	100	8.200	14,5	< 0,98	2,60	< 4,5	5095

**NOTES:**

- (Cn) Tolerance standard value: ±10%. Other tolerance values on request.
- (Cn) - (Un) Capacitance and rated voltage standard values, other values on request.
- (Rs) Releated at 1KHz.
- (R<sub>THS</sub>) Thermal resistance AMBIENT - HOT SPOT (air forced cooling system)
- (I<sub>MAX</sub>) Maximum RMS Current @ 50°C ambient temperature

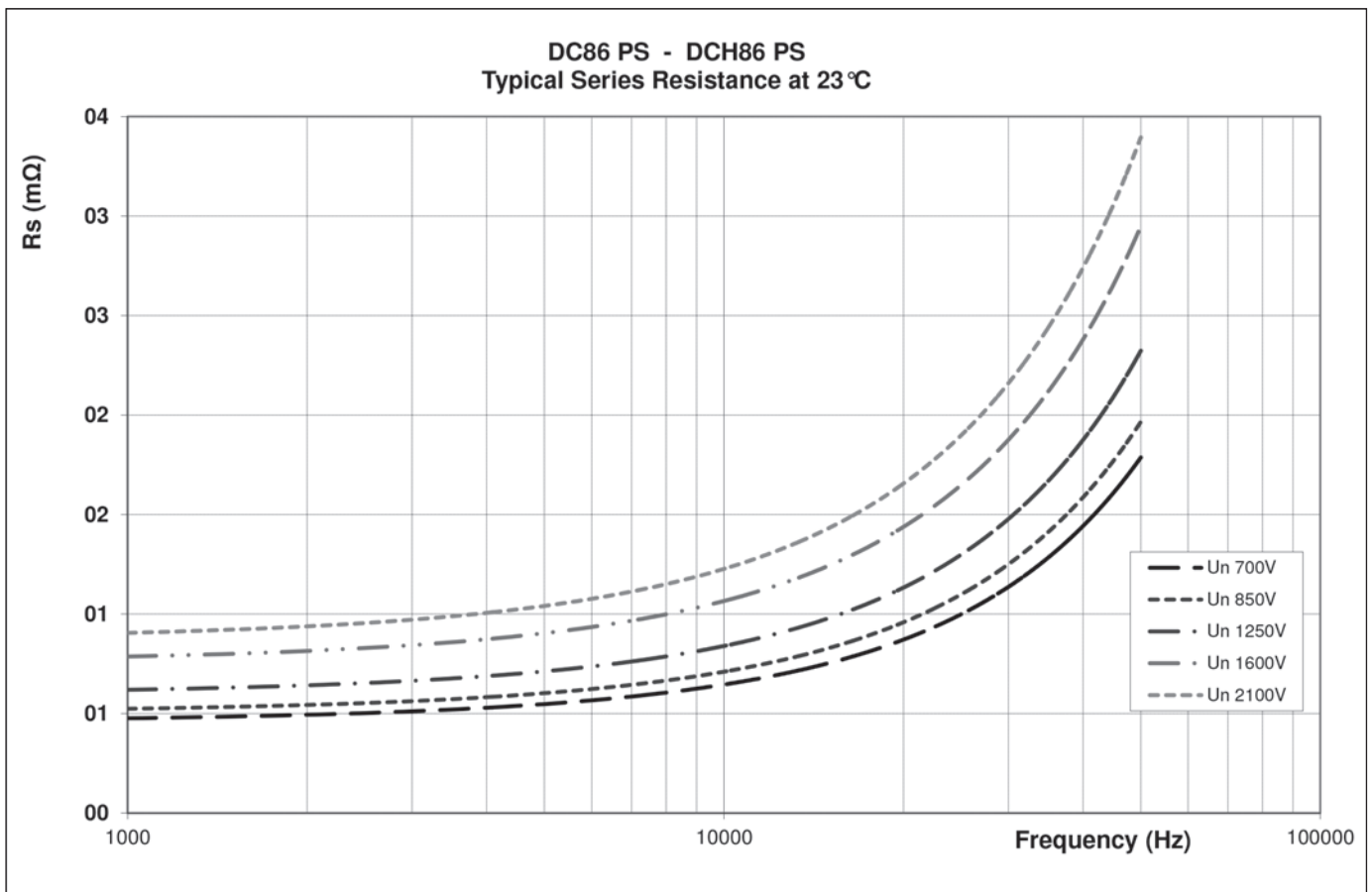

# Power Electronics Capacitors

## DC CAPACITORS

### MECHANICAL SOLUTION:

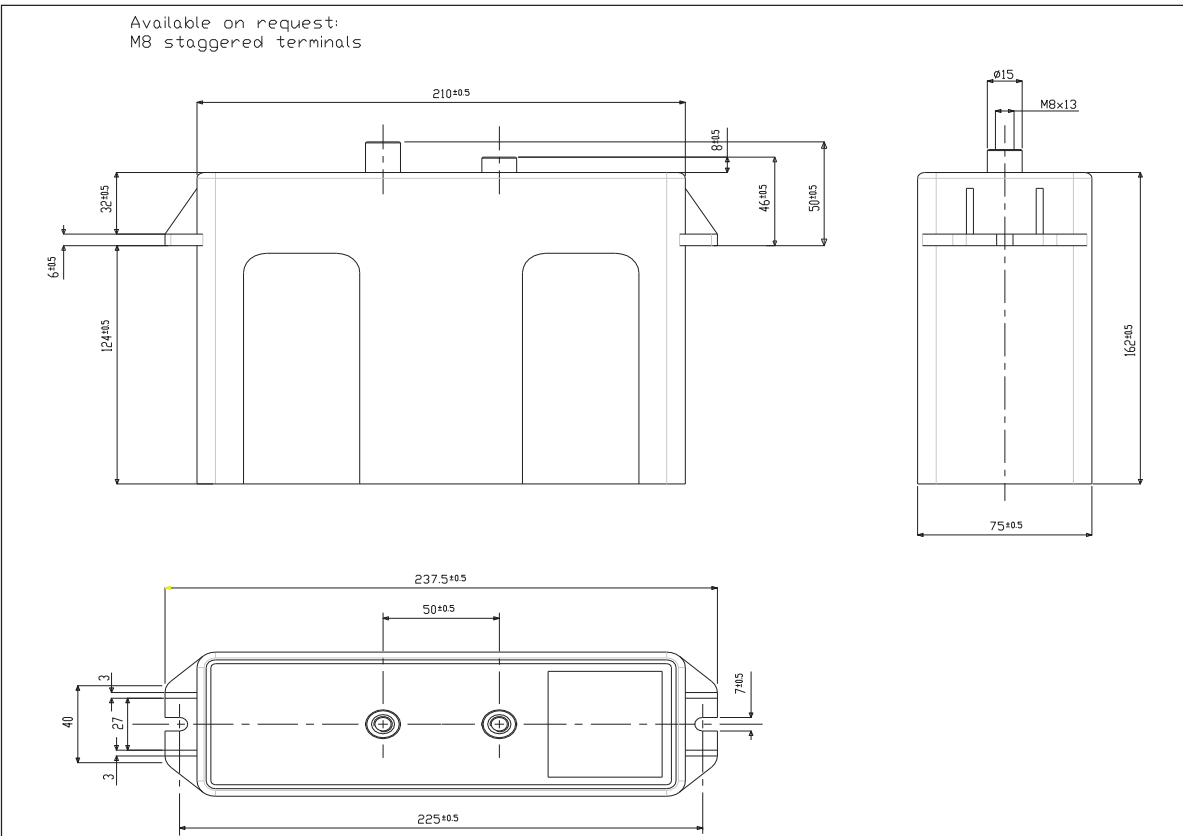
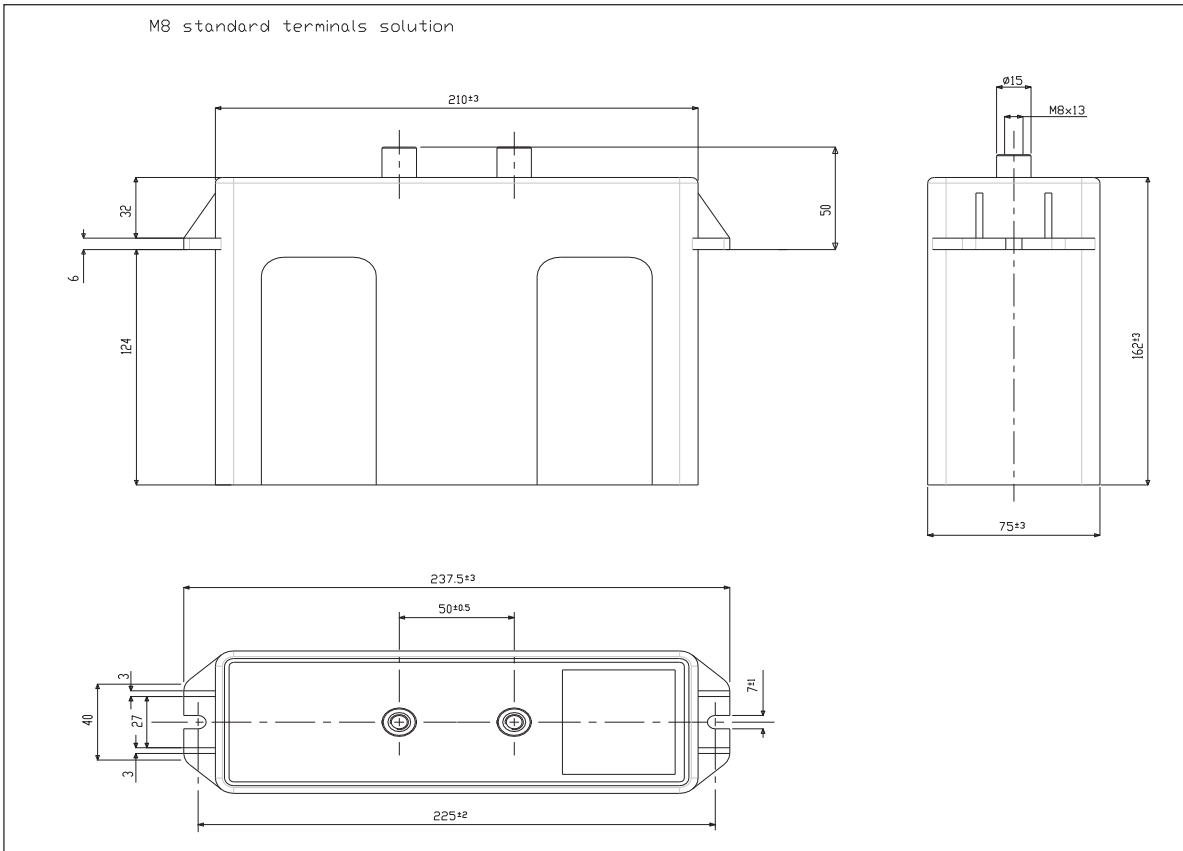

Creepage distance (mm)	35
Clearance distance (mm)	35

#### Box TYPE

Standard box dimensions:  
No. pieces per box:

mm 450 x 470 x 220  
8

## DC CAPACITORS



### **DC 82 P SERIES: Dc - Link and Snubber Capacitor in plastic box case - lead terminals for PCB mounting**

DC Voltage range	450÷1200 V
Maximum ripple voltage	700 V
Maximum ripple current	21 A
Capacitance range	Up to 80 $\mu$ F
Capacitance tolerance	$\pm$ 10% or $\pm$ 5%
Series resistance (Rs)	< 10 m $\Omega$
Maximum Voltage rate of rise (dV/dT)	$\leq$ 100 V/ $\mu$ s
Lead terminal (2 or 4 pin version)	Tinner copper lead for PCB mounting
Voltage test	$U_{tc}$ = 3,5 kVac @50Hz 10s $U_{tt}$ = 1,5 x $U_{nDC}$ 10s
Climatic Ambient Temperature	-25 / +60 $^{\circ}$ C
Operating temperature ( $\theta_{MIN}$ – $\theta_{MAX}$ )	-25 / +105 $^{\circ}$ C
Storage temperature	-25 / +85 $^{\circ}$ C
Filling	Dry epoxy resin UL94V0
Dielectric	Self healing PPMd film
Case	PBT plastic box
Failure quota	100/10E9
Life expectancy	100.000 h (**)
Maximum altitude	2000 m a.s.l.
Reference standard	IEC 1071-1/2 IEC 1881 UL 810

(\*\*) For details please refer to page 10

# Power Electronics Capacitors

## DC CAPACITORS

### DC82 P SERIES - STANDARD TYPE -

RATED DC Voltage [Un <sub>DC</sub> ] = 450V						Repetitive Peak Voltage [Up] = 670V				Surge Voltage [Us] = 900V		
Capacitance (1) Cn [μF] ±10%	Box dimension (3)					Pin	I <sub>RMS</sub> [A] (4)		Ip[KVA]	ESR	Weight	Part number
	W [mm]	H [mm]	L [mm]	P1 [mm]	P2 [mm]	Ø D [mm]	2 Pins	4 Pins	Repetitive	[m ] (2)	[g]	416.82.3 (5)
10,0	17	28	42,5	37,5	-	0,8	9,0	-	0,70	< 10,5	30	10x
12,0	19	32	41,5	37,5	-	0,8	12,0	-	0,72	< 8,5	30	12x
16,0	22	30	42,5	37,5	10,2	0,8 - 1,0	11,0	11,5	0,96	< 7,5	40	16x
12,0	22	37	32	27,5	10,2	0,8 - 1,0	12,0	13,0	0,66	< 6,0	30	12x
20,0	22	33,5	42,5	37,5	10,2	0,8 - 1,0	12,0	13,0	0,70	< 5,5	40	20x
28,0	28	37	42,5	37,5	10,2	0,8 - 1,0	15,0	16,0	0,84	< 5,0	50	28x
34,0	30	45	42,5	37,5	20,3	1,2	17,0	18,5	0,51	< 5,0	70	34x
50,0	30	45	57,5	52,5	20,3	1,2	15,5	16,5	0,65	< 4,5	90	50x
75,0	35	50	57,5	52,5	20,3	1,2	19,0	20,5	0,98	< 4,5	120	75x

RATED DC Voltage [Un <sub>DC</sub> ] = 700V						Repetitive Peak Voltage [Up] = 1050V				Surge Voltage [Us] = 1400V		
Capacitance (1) Cn [μF] ±10%	Box dimension (3)					Pin	I <sub>RMS</sub> [A] (4)		Ip[KVA]	ESR	Weight	Part number
	W [mm]	H [mm]	L [mm]	P1 [mm]	P2 [mm]	Ø D [mm]	2 Pins	4 Pins	Repetitive	[m ] (2)	[g]	416.82.5 (5)
8,0	17	28	42,5	37,5	-	0,8 - 1,0	9,0	-	0,56	< 13,0	30	08x
10,0	19	32	41,5	37,5	-	0,8 - 1,0	12,0	-	0,60	< 12,5	30	10x
14,0	22	30	42,5	37,5	10,2	0,8 - 1,0	11,0	11,5	0,84	< 10,5	40	14x
10,0	22	37	32	27,5	10,2	0,8 - 1,0	12,0	13,0	0,55	< 8,5	30	10x
14,0	22	33,5	42,5	37,5	10,2	0,8 - 1,0	12,0	13,0	0,49	< 7,5	40	14x
22,0	28	37	42,5	37,5	10,2	0,8 - 1,0	15,0	16,0	0,66	< 6,0	50	22x
28,0	30	45	42,5	37,5	20,3	1,2	17,0	18,5	0,42	< 5,5	70	28x
40,0	30	45	57,5	52,5	20,3	1,2	15,0	15,5	0,60	< 5,0	90	40x
55,0	35	50	57,5	52,5	20,3	1,2	19,0	20,5	0,72	< 4,5	120	55x

RATED DC Voltage [Un <sub>DC</sub> ] = 800V						Repetitive Peak Voltage [Up] = 1200V				Surge Voltage [Us] = 1600V		
Capacitance (1) Cn [μF] ±10%	Box dimension (3)					Pin	I <sub>RMS</sub> [A] (4)		Ip[KVA]	ESR	Weight	Part number
	W [mm]	H [mm]	L [mm]	P1 [mm]	P2 [mm]	Ø D [mm]	2 Pins	4 Pins	Repetitive	[m ] (2)	[g]	416.82.6 (5)
6,5	17	28	42,5	37,5	-	0,8 - 1,0	8,0	-	0,49	< 32,0	30	06x
8,0	19	32	41,5	37,5	-	0,8 - 1,0	10,0	-	0,52	< 20,0	30	08x
10,0	22	30	42,5	37,5	10,2	0,8 - 1,0	9,5	10,5	0,65	< 13,0	40	10x
8,0	22	37	32	27,5	10,2	0,8 - 1,0	10,0	11,0	0,48	< 12,5	30	08x
10,0	22	33,5	42,5	37,5	10,2	0,8 - 1,0	10,0	11,0	0,40	< 10,5	40	10x
16,0	28	37	42,5	37,5	10,2	0,8 - 1,0	11,0	12,0	0,56	< 8,5	50	16x
22,0	30	45	42,5	37,5	20,3	1,2	15,5	16,5	0,44	< 7,5	70	22x
34,0	30	45	57,5	52,5	20,3	1,2	14,5	16,0	0,51	< 6,0	90	34x
45,0	35	50	57,5	52,5	20,3	1,2	17,0	18,0	0,59	< 5,0	120	45x

RATED DC Voltage [Un <sub>DC</sub> ] = 900V						Repetitive Peak Voltage [Up] = 1350V				Surge Voltage [Us] = 1800V		
Capacitance (1) Cn [μF]	Box dimension (3)					Pin	I <sub>RMS</sub> [A] (4)		Ip[KVA]	ESR	Weight	Part number
	W [mm]	H [mm]	L [mm]	P1 [mm]	P2 [mm]	Ø D [mm]	2 Pins	4 Pins	Repetitive	[m ] (2)	[g]	416.82.7 (5)
5,0	17	28	42,5	37,5	-	0,8 - 1,0	9,0	-	0,40	< 35,0	30	05x
7,0	19	32	41,5	37,5	-	0,8 - 1,0	9,0	-	0,49	< 20,0	30	07x
8,5	22	30	42,5	37,5	10,2	0,8 - 1,0	8,0	8,5	0,60	< 13,0	40	08x
6,5	22	37	32	27,5	10,2	0,8 - 1,0	9,5	10,5	0,43	< 14,0	30	06x
10,0	22	33,5	42,5	37,5	10,2	0,8 - 1,0	11,0	11,5	0,45	< 12,5	40	10x
14,0	28	37	42,5	37,5	10,2	0,8 - 1,0	12,0	13,0	0,56	< 9,5	50	14x
18,0	30	45	42,5	37,5	20,3	1,2	14,0	16,0	0,36	< 8,0	70	18x
28,0	30	45	57,5	52,5	20,3	1,2	13,0	13,5	0,42	< 7,0	90	28x
35,0	35	50	57,5	52,5	20,3	1,2	16,0	17,0	0,53	< 6,0	120	35x

- (1) Intermediate capacitance values available on request.
- (2) Equivalent series resistance @5KHz - referred to 4 pins configuration, when available.
- (3) Standard box dimension, other type on request.
- (4) Maximum RMS current at 5kHz
- (5) Last three digit of the code according to: capacitance and tolerance value, mechanical configuration and terminals

# Power Electronics Capacitors

## DC CAPACITORS

### DC82 P SERIES - STANDARD TYPE -

RATED DC Voltage [ $U_{DC}$ ] = 1100V						Repetitive Peak Voltage [ $U_p$ ] = 1650V				Surge Voltage [ $U_s$ ] = 2200V		
Capacitance <sup>(1)</sup> Cn [ $\mu$ F]	Box dimension <sup>(3)</sup>					Pin $\varnothing$ D [mm]	$I_{RMS}$ [A] <sup>(4)</sup>		Ip[KVA] Repetitive	ESR [m $\Omega$ ] <sup>(2)</sup>	Weight [g]	Part number 416.82.8. (5)
	W [mm]	H [mm]	L [mm]	P1 [mm]	P2 [mm]		2 Pins	4 Pins				
3,5	17	28	42,5	37,5	-	0,8 - 1,0	6,5	-	0,34	< 42,0	30	03x
4,5	19	32	41,5	37,5	-	0,8 - 1,0	8,0	-	0,43	< 23,0	30	04x
6,0	22	30	42,5	37,5	10,2	0,8 - 1,0	6,5	7,0	0,57	< 15,0	40	06x
4,5	22	37	32	27,5	10,2	0,8 - 1,0	8,0	8,5	0,36	< 16,5	30	04x
6,5	22	33,5	42,5	37,5	10,2	0,8 - 1,0	9,5	10,0	0,36	< 14,0	40	06x
10,0	28	37	42,5	37,5	10,2	0,8 - 1,0	11,0	12,0	0,45	< 10,0	50	10x
12,0	30	45	42,5	37,5	20,3	1,2	13,0	14,0	0,28	< 8,5	70	12x
18,0	30	45	57,5	52,5	20,3	1,2	14,0	14,5	0,42	< 8,0	90	18x
26,0	35	50	57,5	52,5	20,3	1,2	15,0	16,0	0,52	< 6,5	120	23x

RATED DC Voltage [ $U_{DC}$ ] = 1200V						Repetitive Peak Voltage [ $U_p$ ] = 1800V				Surge Voltage [ $U_s$ ] = 2400V		
Capacitance <sup>(1)</sup> Cn [ $\mu$ F]	Box dimension <sup>(3)</sup>					Pin $\varnothing$ D [mm]	$I_{RMS}$ [A] <sup>(4)</sup>		Ip[KVA] Repetitive	ESR [m $\Omega$ ] <sup>(2)</sup>	Weight [g]	Part number 416.82.9. (5)
	W [mm]	H [mm]	L [mm]	P1 [mm]	P2 [mm]		2 Pins	4 Pins				
3,0	17	28	42,5	37,5	-	0,8 - 1,0	6,5	-	0,30	< 45,0	30	03x
3,5	19	32	41,5	37,5	-	0,8 - 1,0	8,0	-	0,35	< 25,0	30	03x
5,5	22	30	42,5	37,5	10,2	0,8 - 1,0	6,5	7,0	0,55	< 15,0	40	05x
3,0	22	37	32	27,5	10,2	0,8 - 1,0	8,0	8,5	0,30	< 18,0	30	03x
5,0	22	33,5	42,5	37,5	10,2	0,8 - 1,0	9,5	10,0	0,30	< 15,0	40	05x
7,5	28	37	42,5	37,5	10,2	0,8 - 1,0	11,0	12,0	0,38	< 10,5	50	07x
12,0	30	45	42,5	37,5	20,3	1,2	13,0	14,0	0,30	< 9,0	70	12x
16,0	30	45	57,5	52,5	20,3	1,2	14,0	14,5	0,40	< 8,5	90	16x
22,0	35	50	57,5	52,5	20,3	1,2	15,0	16,0	0,55	< 7,0	120	22x

- (1) Intermediate capacitance values available on request.
- (2) Equivalent series resistance @5KHz - referred to 4 pins configuration, when available.
- (3) Standard box dimension, other type on request.
- (4) Maximum RMS current at 5kHz
- (5) Last three digit of the code according to: capacitance and tolerance value, mechanical configuration and terminals

Specific reference data at 85°C working temperature  
For different temperature, please see the following derating:

	Temp.	[V]	[V]	[V]	[V]	[V]	[V]
$U_{op}$	70 °C	500	800	900	1100	1350	1500
$U_{DC}$	85 °C	450	700	800	900	1100	1200
$U_{op}$	105 °C	300	500	550	650	800	850

Mechanical configuration (4 pins):  
4 pin version

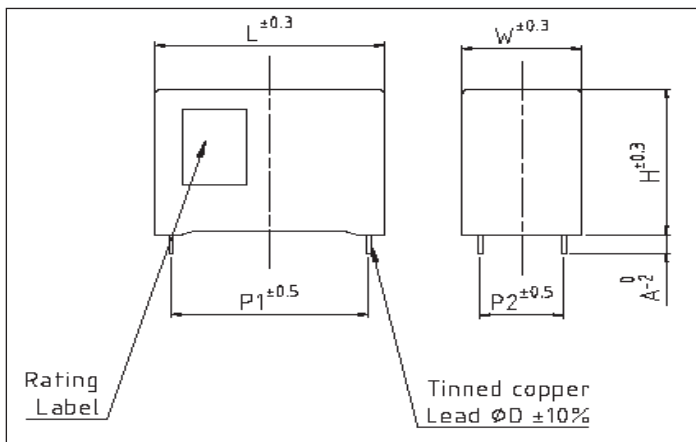

2 pin version

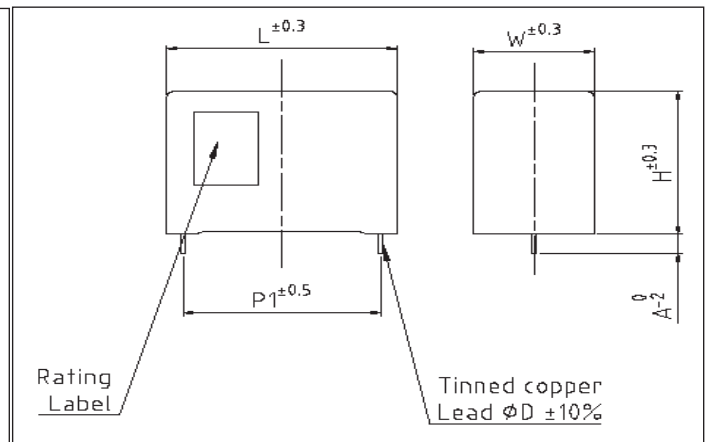

Typical lead version:

Version	Spacing (*)		Diameter	High (*)
# pin	P1 (mm)	P2 (mm)	ØD (mm)	A (mm)
2	27,5 / 37,5	-	0,8 - 1,0	6
4	27,5 / 37,5	10,2	0,8 - 1,0	6
4	37,5 / 52,5	20,3	1,2	6

(\*) Typical dimension and configuration, other values on request

### Mounting guidelines

Solder bath temperature  $235 \pm 5 \text{ }^\circ\text{C}$

Soldering time  $2.0 \pm 0.5 \text{ s}$  (for lead spacings  $< 10,2 \text{ mm}$ )

Immersion depth  $2.0 \pm 0.5 \text{ mm}$  from capacitor body or seating plane

The solderability of terminal leads is tested to IEC 60068-2-20, test Ta, method 1.

DUCATI recommends the following conditions:

Pre-heating with a maximum temperature of  $110 \text{ }^\circ\text{C}$ ,

Temperature inside the capacitor should not exceed  $110 \text{ }^\circ\text{C}$

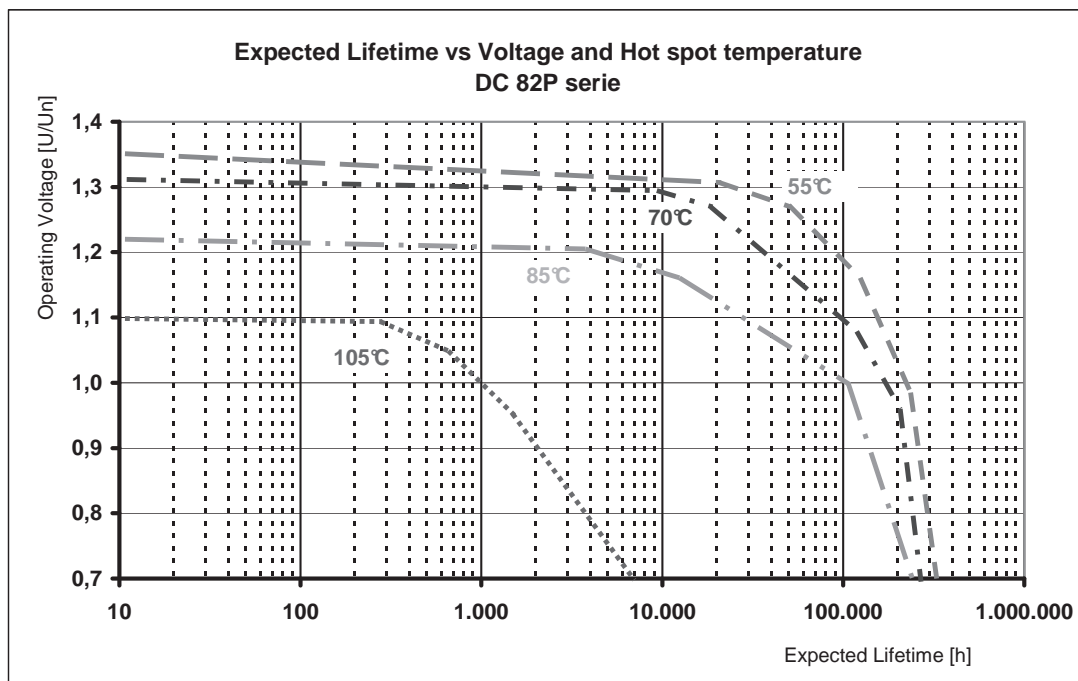
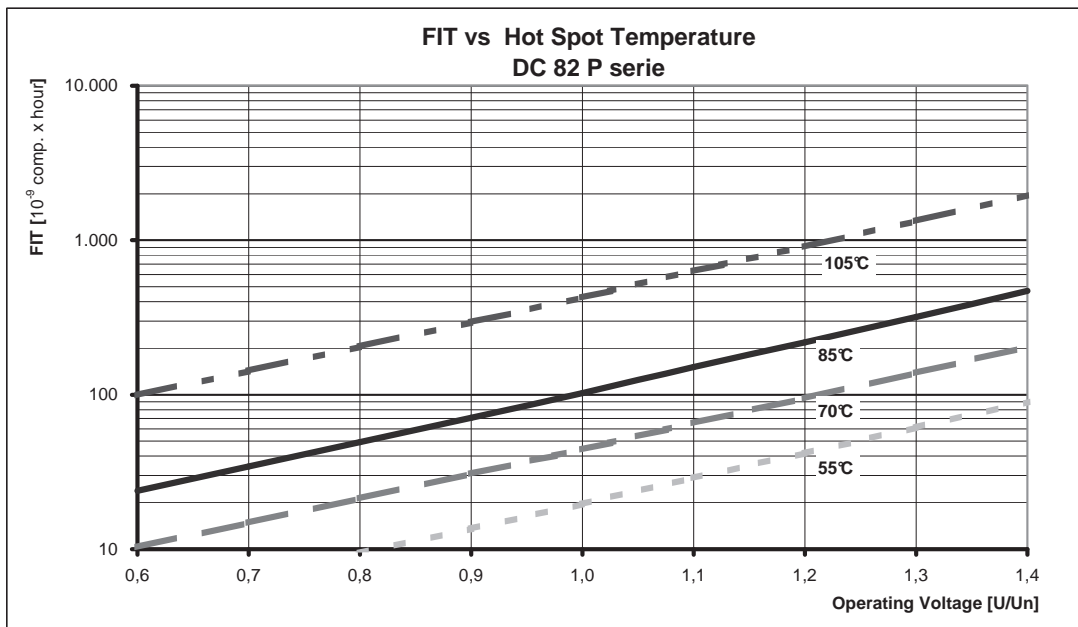

## DC CAPACITORS



### **DC 85 C SERIES:** **Dc - Link Capacitors in cylindrical can**

DC Voltage range	550÷1800 V
Maximum ripple voltage	1150 V
Maximum ripple current	100 A
Capacitance range	Up to 4450 $\mu$ F
Capacitance tolerance	+0% / -15%
Series resistance ( $R_s$ )	< 4,5 m $\Omega$
Maximum Voltage rate of rise (dV/dT)	$\leq$ 40 V/ $\mu$ s
Terminals	M6 internal threads M8 screw types bolts
Voltage test	$U_{tc}$ = 3,5 kVac @50Hz 10s $U_{tt}$ = 1,5 x $U_{nDC}$ 10s
Climatic Ambient Temperature	-25 / +45 °C
Working temperature ( $\theta_{MIN}$ – $\theta_{MAX}$ )	-25 / +85 °C
Storage temperature	-25 / +85 °C
Filling	Dry polyurethane resin
Dielectric	Self healing PPMd film
Cylindrical case	Aluminum
Failure quota	50/10E9
Life expectancy	100.000 h
Maximum altitude	2000 m a.s.l.
Reference standard	IEC 1071-1/2 IEC 1881 UL 810
Internal thread terminals	Max 3 Nm
M8 screw terminals	Max 6 Nm
M12 fixing bolt	Max 12 Nm
UL - CSA approved (c  us)	File n. E192559

**Safety system:** These capacitors are designed with a particular type of polypropylene metalized film (PPMd film) that assures an open circuit at the end of life, if the operation is within the specification.

(\*\*) For details please refer to page 10



# Power Electronics Capacitors

## DC CAPACITORS

### DC85 C SERIES

Capacitance Cn [uF]	Diameter Ø [mm]	Height H [mm]	Max. RMS Current I <sub>MAX</sub> [A]	Repet. Peak Current Ip [A]	Surge Current Is [kA]	Series Resistance Rs [mΩ]	Thermal Resistance R <sub>THC</sub> [°C/W]	Series Inductance Lesr [nH]	Weight [Kg]	Pcs. / Box - Box type	Part number 416.85.
<b>Un [V] = 550V<sub>DC</sub></b>			<b>Ur [V] = 230V</b>			<b>Up [V] = 850V</b>			<b>Us [V] = 1160V</b>		
500	75	105	25	1500	5,0	3,8	5,4	< 45	0,6	12 - A	L09.x
760	75	140	30	2200	6,5	3,6	4,8	< 50	0,8	6 - B	L19.x
870	75	155	35	2200	7,0	3,0	4,6	< 60	0,9	6 - B	L29.x
1.000	85	140	35	3000	7,5	2,9	4,2	< 50	1,0	6 - B	L39.x
1.150	85	155	40	3000	9,0	2,7	3,6	< 60	1,1	6 - B	L49.x
1.850	100	185	65	3700	11,0	1,6	2,6	< 60	1,8	6 - C	L55.x
2.550	116	185	70	4000	12,0	1,4	2,3	< 60	2,3	4 - G	L59.X
2.800	100	255	70	4200	13,0	1,2	2,3	< 75	2,4	6 - D	L69.x
3.900	116	255	75	5800	15,0	1,0	2,1	< 75	3,2	4 - G	L79.x
4.450	116	285	80	6700	18,0	0,8	1,7	< 80	3,6	4 - G	L89.x
<b>Un [V] = 700V<sub>DC</sub></b>			<b>Ur [V] = 320V</b>			<b>Up [V] = 1050V</b>			<b>Us [V] = 1470V</b>		
370	75	105	28	2200	6,6	3,9	5,4	< 45	0,6	12 - A	009.x
560	75	140	30	2800	8,4	3,7	4,8	< 50	0,8	6 - B	019.x
640	75	155	35	3200	9,6	3,2	4,6	< 60	0,9	6 - B	029.x
740	85	140	35	3300	10,0	3,1	4,2	< 50	1,0	6 - B	039.x
830	90	140	40	3500	10,0	3,0	4,0	< 50	1,1	6 - B	039.x
850	85	155	40	3800	11,5	2,9	3,6	< 60	1,1	6 - B	049.x
1.350	100	185	65	5400	16,0	1,8	2,6	< 60	1,8	6 - C	055.x
1.900	116	185	70	6600	20,0	1,7	2,3	< 60	2,3	4 - G	059.x
2.350	100	255	70	7000	21,0	1,6	2,3	< 75	2,4	6 - D	069.x
2.850	116	255	75	7100	21,0	1,3	2,1	< 75	3,2	4 - G	079.x
3.300	116	285	85	8200	24,5	1,2	1,7	< 80	3,5	4 - G	089.x
<b>Un [V] = 900V<sub>DC</sub></b>			<b>Ur [V] = 550V</b>			<b>Up [V] = 1350V</b>			<b>Us [V] = 1900V</b>		
280	75	105	30	2200	6,7	4,1	5,4	< 45	0,7	12 - A	119.x
430	75	140	35	2400	7,1	3,8	4,8	< 50	0,8	6 - B	139.x
570	85	140	35	3400	10,3	3,6	4,2	< 50	1,0	6 - B	149.x
620	90	140	40	3600	10,3	3,5	4,0	< 50	1,1	6 - B	159.x
650	85	155	40	3900	11,7	3,5	3,6	< 60	1,1	6 - B	169.x
1.050	100	185	65	5300	15,8	2,2	2,6	< 70	1,8	6 - C	179.x
1.450	116	185	70	7300	21,8	2,0	2,3	< 70	2,3	4 - G	185.x
1.550	100	255	70	7800	23,3	1,9	2,3	< 75	2,4	6 - D	189.x
1.800	100	285	75	8100	24,3	1,8	2,2	< 80	2,6	6 - E	191.x
2.200	116	255	75	9900	29,7	1,4	2,1	< 75	3,1	4 - G	193.x
2.350	100	373	100	10500	31,7	1,2	1,8	< 90	3,4	6 - F	195.x
2.500	116	285	85	10000	30,0	1,5	1,7	< 80	3,5	4 - G	197.x
3.300	116	373	100	11550	30,0	1,1	1,6	< 90	4,6	4 - H	199.x
<b>Un [V] = 1100V<sub>DC</sub></b>			<b>Ur [V] = 700V</b>			<b>Up [V] = 1650V</b>			<b>Us [V] = 2300V</b>		
180	75	105	30	2160	6,5	4,2	5,4	< 45	0,6	12 - A	219.X
270	75	140	35	3240	9,7	3,9	4,8	< 50	0,8	6 - B	229.X
370	85	140	35	3960	11,9	3,7	4,2	< 50	1,0	6 - B	239.X
420	85	155	40	4200	12,6	3,6	3,6	< 60	1,1	6 - B	250.X
510	90	185	65	5200	16,0	3,1	2,8	< 70	1,6	6 - C	255.X
650	100	185	65	5850	17,6	2,3	2,6	< 70	1,8	6 - C	260.X
900	116	185	70	8100	24,3	2,1	2,3	< 70	2,3	4 - G	265.X
1.000	100	255	70	8500	25,5	2,0	2,3	< 75	2,4	6 - D	270.X
1.200	100	285	75	9200	27,6	1,9	2,2	< 80	2,6	6 - E	280.X
1.400	116	255	75	11900	30,0	1,7	2,1	< 75	3,2	4 - G	285.X
1.500	100	373	100	13500	32,0	1,3	1,8	< 90	3,4	6 - F	289.X
1.600	116	285	85	12800	32,0	1,7	1,7	< 80	3,5	4 - G	293.X
2.400	116	373	100	14400	32,0	1,3	1,6	< 90	4,4	4 - H	298.X

# Power Electronics Capacitors

## DC CAPACITORS

### DC85 C SERIES

Capacitance Cn [uF]	Diameter Ø [mm]	Height H [mm]	Max. RMS Current I <sub>MAX</sub> [A]	Repet. Peak Current Ip [A]	Surge Current Is [kA]	Series Resistance Rs [mΩ]	Thermal Resistance R <sub>THC</sub> [°C/W]	Series Inductance Lesr [nH]	Weight [Kg]	Pcs. / Box - Box type	Part number 416.85.
<b>Un [V] = 1300V<sub>DC</sub></b>			<b>Ur [V] = 850V</b>			<b>Up [V] = 1950V</b>			<b>Us [V] = 2700V</b>		
120	75	105	30	2160	6,5	4,3	5,4	< 45	0,6	12 - A	319.x
180	75	140	35	3240	9,7	4,0	4,8	< 50	0,8	6 - B	320.x
250	85	140	35	4000	12,0	3,9	4,2	< 50	1,0	6 - B	330.x
270	90	140	40	4200	12,0	3,8	4,0	< 50	1,1	6 - B	335.x
300	85	155	40	4480	13,5	3,7	3,6	< 60	1,1	6 - B	340.x
470	100	185	65	7200	21,6	2,3	2,6	< 70	1,8	6 - C	350.x
550	90	255	70	8500	25,0	2,2	2,4	< 70	2,3	6 - D	353.x
650	116	185	70	9750	29,5	2,2	2,3	< 70	2,3	4 - G	355.x
700	100	255	70	9800	30,0	2,1	2,3	< 75	2,4	6 - D	360.x
800	100	285	75	11200	32,0	2,0	2,2	< 80	3,1	6 - E	370.x
980	116	255	75	12740	32,0	1,8	2,1	< 75	3,2	4 - G	375.x
1.000	100	373	100	12600	32,0	1,3	1,8	< 90	3,5	6 - F	399.x
1.150	116	285	85	13800	32,0	1,8	1,7	< 80	3,6	4 - G	385.x
1.450	116	373	100	14500	32,0	1,4	1,6	< 90	4,6	4 - H	388.x
<b>Un [V] = 1550V<sub>DC</sub></b>			<b>Ur [V] = 990V</b>			<b>Up [V] = 2300V</b>			<b>Us [V] = 3000V</b>		
90	75	105	30	2250	6,5	4,4	5,4	< 45	0,6	12 - A	419.x
140	75	140	35	2940	9,7	4,1	4,8	< 50	0,8	6 - B	420.x
180	85	140	35	3600	12,0	4,0	4,2	< 50	1,0	6 - B	430.x
200	85	155	40	4200	13,5	3,8	3,6	< 60	1,1	6 - B	440.x
250	90	155	45	5000	15,0	3,4	3,3	< 60	1,3	6 - B	445.x
350	100	185	65	7000	21,6	2,3	2,6	< 70	2,2	6 - C	450.x
400	90	255	70	7500	25,0	2,2	2,4	< 70	2,3	6 - D	457.x
470	116	185	70	8460	29,5	2,3	2,3	< 70	2,3	4 - G	455.x
500	100	255	70	9000	30,0	2,2	2,3	< 75	2,4	6 - D	460.x
600	100	285	75	9600	32,0	2,0	2,2	< 80	2,6	6 - E	470.x
700	116	255	75	11200	32,0	1,9	2,1	< 75	3,2	4 - G	475.x
750	100	373	100	12000	32,0	1,4	1,8	< 90	3,3	6 - F	480.x
820	116	285	85	13120	32,0	1,9	1,7	< 80	3,7	4 - G	485.x
1.050	116	373	100	14700	32,0	1,4	1,6	< 90	4,6	4 - H	498.x
<b>Un [V] = 1800V<sub>DC</sub></b>			<b>Ur [V] = 1150V</b>			<b>Up [V] = 2700V</b>			<b>Us [V] = 3000V</b>		
60	75	105	30	2100	6,5	4,5	5,4	< 45	0,6	12 - A	510.x
100	75	140	35	3000	9,7	4,2	4,8	< 50	0,8	6 - B	520.x
135	85	140	35	3375	12,0	4,1	4,2	< 50	1,0	6 - B	530.x
150	85	155	40	3450	13,5	3,9	3,6	< 60	1,1	6 - B	540.x
190	90	155	45	3900	15,0	3,4	3,3	< 60	1,3	6 - B	545.x
240	100	185	65	4800	21,6	2,3	2,6	< 70	1,8	6 - C	550.x
310	90	255	70	6500	25,0	2,1	2,4	< 70	2,2	6 - D	553.x
340	116	185	70	6800	29,5	2,2	2,3	< 70	2,2	4 - G	555.x
370	100	255	70	7400	30,0	2,1	2,3	< 75	2,3	6 - D	560.x
430	100	285	75	9600	32,0	2,0	2,2	< 80	2,6	6 - E	570.x
530	116	255	75	10750	32,0	2,0	2,1	< 75	3,3	4 - G	575.x
560	100	373	100	11500	32,0	1,4	1,8	< 90	3,5	6 - F	580.x
610	116	285	85	12500	32,0	1,9	1,7	< 80	3,6	4 - G	585.x
800	116	373	100	14400	32,0	1,5	1,6	< 90	4,6	4 - H	598.x

(Cn) Tolerance standard value: -15 .. +0%. Other tolerance values on request.

(Cn) - (Un) Capacitance and rated voltage standard values, other values on request.

(Ur) Maximum peak to peak alternating voltage component on the DC working voltage.

(Rs) Related to 1 KHz.

(R<sub>THC</sub>) Thermal resistance CASE TO AMBIENT in natural cooling environment.

(I<sub>MAX</sub>) Maximum RMS current, referred to ambient temperature of 50 °C (natural cooling) and a working frequency of 1 KHz.

In case of different temperature, see diagram below.

(x code) According to the terminal type: x = 0 → A SOLUTION (internal thread M6) / x = 1 → B SOLUTION (M8 screw type bolts).

## DC CAPACITORS

### Mechanical standard configuration:

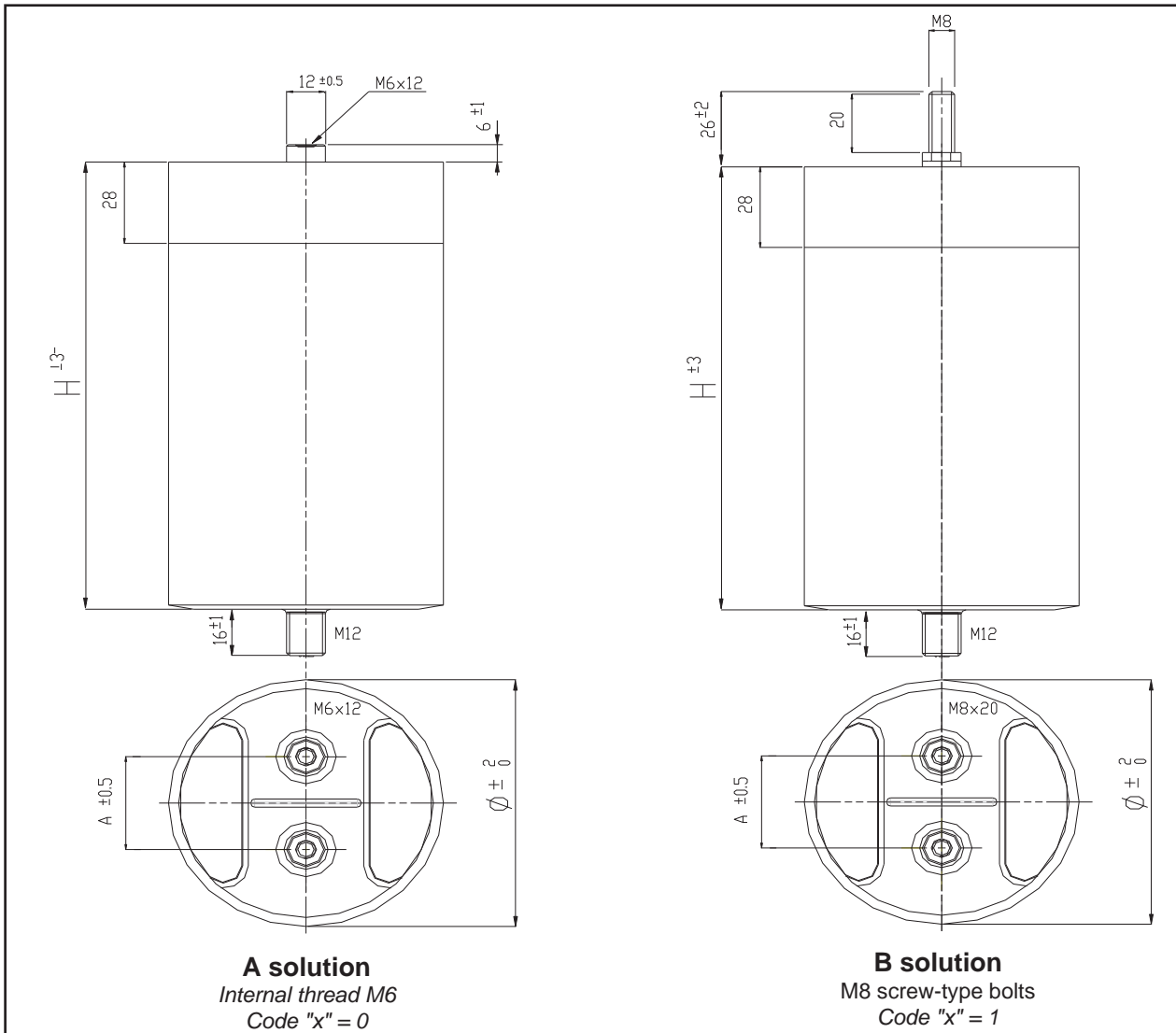

Diameter Ø [mm]	A spacing [mm]	Type of terminal	Insulation spacing	
			Surface [mm]	Air [mm]
From 75 to 100	32	M6 female / M8 male	36	20
90	45 (*)	M6 female / M8 male	49	33
116	50	M6 female / M8 male	54	38

(\*) Available also in the dimension: 32 - 50 mm

### Terminal type on request:

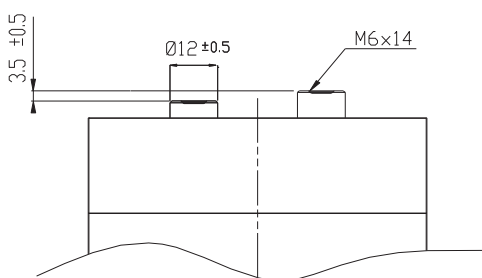

Two different terminals height for special BUS BAR coupling.

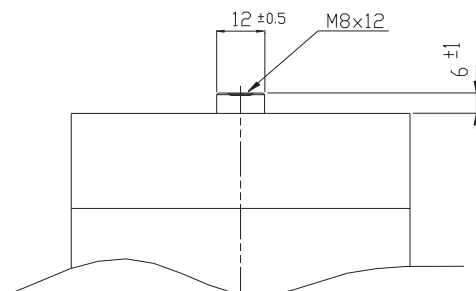

Available M8 internal thread on the same terminal dimension.

# DC CAPACITORS

## DCH 85 C Series

Box Type	Box Type Dimensions
A	mm 190 x 285 x 280
B	mm 190 x 285 x 200
C	mm 220 x 335 x 265
D	mm 220 x 335 x 325
E	mm 220 x 335 x 375
F	mm 220 x 335 x 450
G	mm 270 x 270 x 380
H	mm 270 x 270 x 450

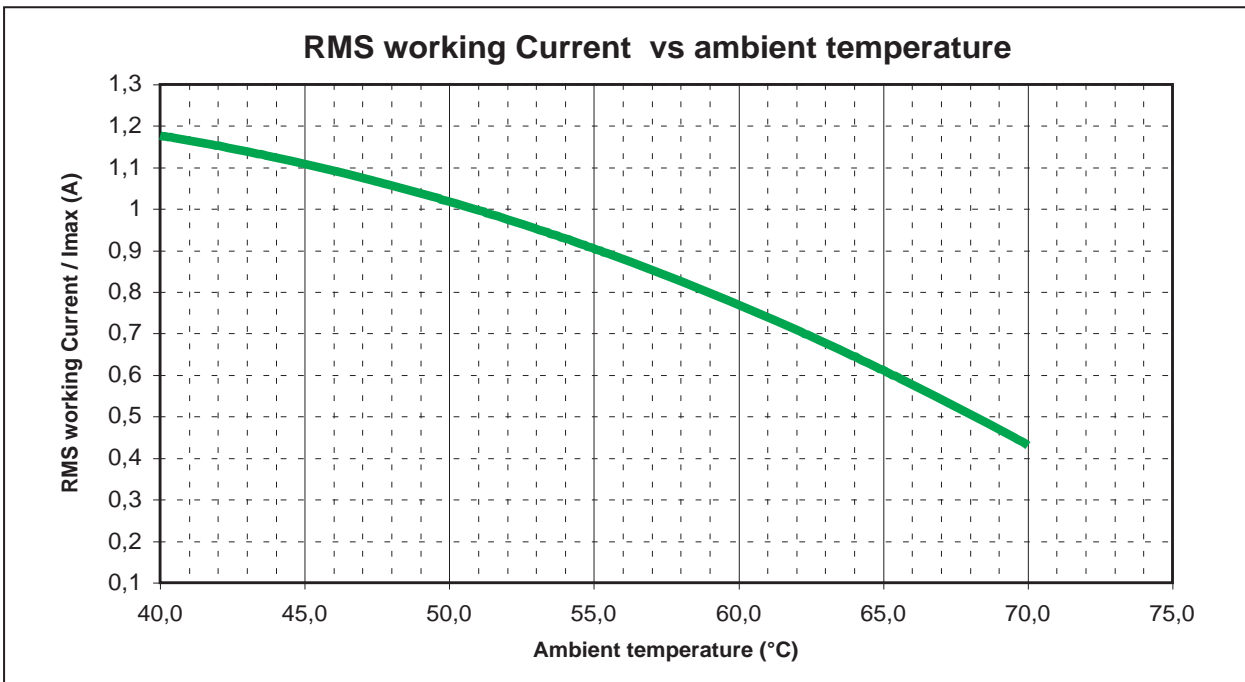

## DC CAPACITORS



### **DC 85 B SERIES:** **Dc - Link Capacitors on cubic box**

DC Voltage range	550÷6000 V
Maximum ripple current	120 A
Capacitance range	Up to 38000 µF
Capacitance tolerance	+0% / -15%
Series resistance (R <sub>s</sub> )	< 5 mΩ
Thermal resistance natural cooling (R <sub>THC</sub> )	2,0 °C/W
Equivalent series inductance (L <sub>ESR</sub> )	< 30 nH
Terminals	M10 screw-type bolts
Test voltage	U <sub>tt</sub> = 1.5 x U <sub>nDC</sub> 10s
Climatic Ambient Temperature	-25 / +45 °C
Working temperature (θ <sub>MIN</sub> – θ <sub>MAX</sub> )	-25 / +85 °C
Storage temperature	-25 / +85 °C
Filling	Self-extinguishing (UL94 V0) polyurethane resin
Dielectric	Self healing PPMd film
Container	Self-extinguishing (UL94 V0) plastic box
Failure quota	50/10E9
Life expectancy	100.000 h (**)
Maximum altitude	2000 m a.s.l.
Reference standard	IEC 1071-1/2 IEC 1881 UL 810
M10 screw terminals	Max 10 Nm
Fixing slots	Max 10 Nm

**Safety system:** These capacitors are designed with a particular type of polypropylene metalized film (PPMd film) that assures an open circuit at the end of life, if the operation is within the specification.

(\*\*) For details please refer to page 10

# Power Electronics Capacitors

## DC CAPACITORS

### DC 85 B Series

Capacitance Cn [ $\mu$ F]	Rated DC Voltage Un [V]	Repet. Peak Voltage Up [kV]	Surge Voltage Us [kV]	Max. RMS Current Imax [A]	Repet. Peak Current Ip [A]	Surge Current Is [kA]	Series Resistance Rs [m $\Omega$ ]	Thermal Resistance R <sub>THC</sub> [ $^{\circ}$ C/W]	Weight [kg]	Terminal solution A / B	Part number 416.85.
3.800	550	0,8	1,2	120	9800	25	< 0,80	1,65	< 5,0	A / B	001.X
2.800	650	1,0	1,4	120	9300	25	< 0,80	1,65	< 5,0	A / B	005.X
2.250	750	1,1	1,6	120	9500	25	< 0,80	1,65	< 5,0	A / B	090.X
1.500	900	1,4	1,9	120	9500	25	< 0,80	1,65	< 5,0	A / B	190.X
1.200	1100	1,7	2,3	120	9600	25	< 0,80	1,65	< 5,0	A / B	290.X
1.000	1250	1,9	2,6	120	9000	20	< 0,85	1,65	< 5,0	A / B	390.X
800	1350	2,0	2,9	100	8800	20	< 1,20	1,65	< 5,0	A / B	405.X
750	1450	2,2	3,0	100	8500	20	< 1,20	1,65	< 5,0	A / B	490.X
420	1800	2,7	3,8	100	8200	15	< 1,20	1,65	< 5,0	A / B	590.X
280	2200	3,3	4,6	80	7000	15	< 1,80	1,65	< 5,0	A / B	690.X
180	2800	4,2	5,8	80	6300	15	< 1,90	1,65	< 5,0	A / B	790.X
80	4000	6,0	8,5	60	4000	10	< 3,20	1,65	< 5,0	A / B	890.X
50	5000	7,5	10,0	50	3500	10	< 4,60	1,65	< 5,0	A / B	990.X
40	5500	8,3	10,0	40	3200	8	< 7,50	1,65	< 5,0	A / B	A90.X
30	6000	9,0	10,0	35	2700	8	< 8,20	1,65	< 5,0	A / B	B90.X

- (Cn) Tolerance standard value: -15 + 0%. Other tolerance values on request.  
 (Cn) - (Un) Capacitance and rated voltage standard values, other values on request.  
 (Rs) Related to 1KHz.  
 (R<sub>THC</sub>) Thermal resistance CASE TO AMBIENT in natural cooling environment.  
 (A/B solut.) .X = "5" for A solution (M10 terminals on surface without handles) / .X = "6" for B solution (M10 terminals on handle surface)"

<b>Box TYPE</b>	
<b>Standard box dimensions</b>	mm 450 x 470 x 220
<b>No. pieces x box:</b>	4

### TERMINAL TYPES

Standard length value for M10 terminals:

- 19 mm
- 34 mm

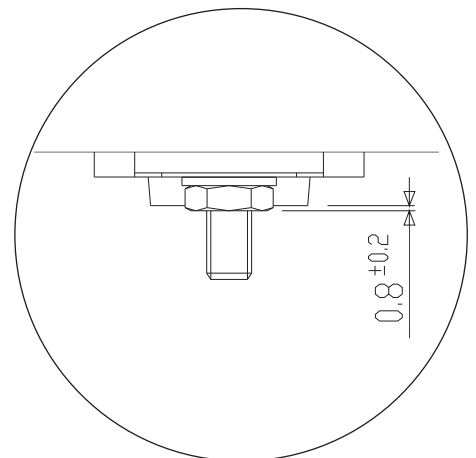
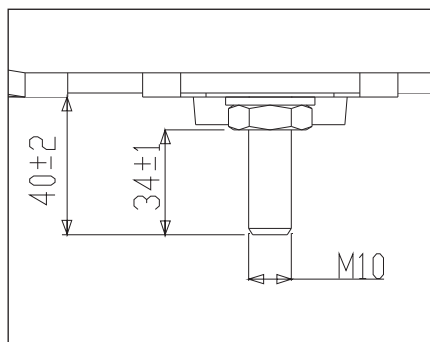
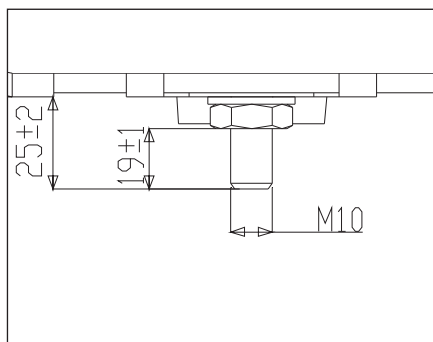

DC CAPACITORS

DC 85 B Series

TERMINAL SOLUTIONS:

**A SOLUTION:**  
41685.xxx.5

M10 terminals on surface without handles

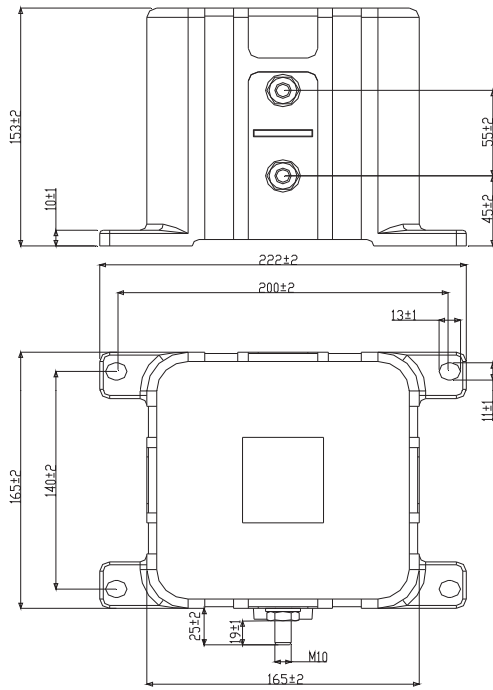

**B SOLUTION:**  
41685.xxx.6

M10 terminals on handle surface

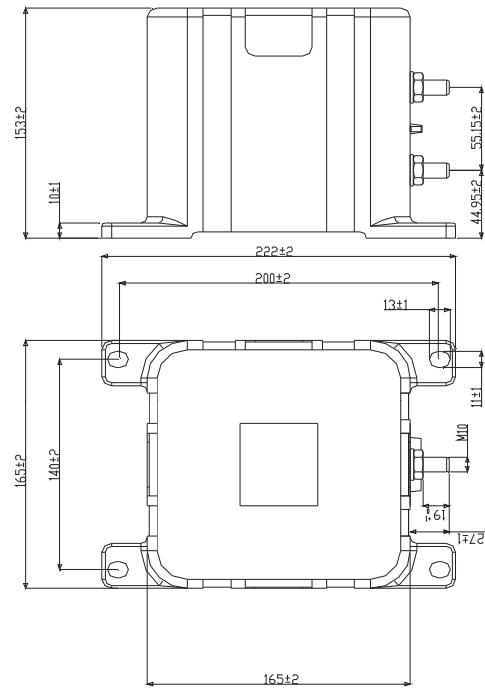



## DC CAPACITORS

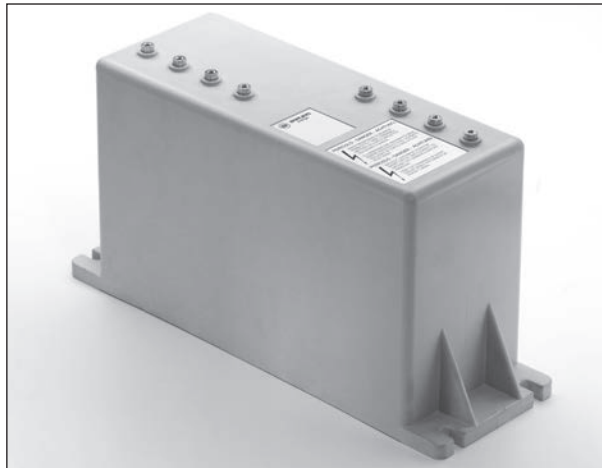

### **DC 86 P SERIES:** **Dc - Link Capacitors in prismatic box**

DC Voltage range	550÷6800 V
Maximum ripple current	300 A
Capacitance range	Up to 15000 µF
Capacitance tolerance	+0% / -15%
Thermal resistance natural cooling (R <sub>THC</sub> )	0,52 °C/W
Equivalent series inductance (L <sub>ESR</sub> )	< 45 nH
Terminals	4 x M6 internal threads per pole or bus-bars
Test voltage	U <sub>tc</sub> = 12 kVac @50 Hz 60s U <sub>tt</sub> = 1,5 x U <sub>nDC</sub> 10s
Climatic Ambient Temperature	-25 / +45 °C
Working temperature (θ <sub>MIN</sub> – θ <sub>MAX</sub> )	-25 / +85 °C
Storage temperature	-25 / +85 °C
Filling	Self-extinguishing (UL94 V0) polyurethane resin
Dielectric	Self healing PPMd film
Container	Self-extinguishing (UL94 V0) plastic box
Failure quota	50/10E9
Life expectancy	100.000 h (**)
Maximum altitude	2000 m a.s.l.
Reference standard	IEC 1071-1/2 IEC 1881 UL 810
M6 internal thread terminals	Max 3 Nm
Fixing slots	Max 10 Nm

**Safety system:** These capacitors are designed with a particular type of polypropylene metalized film (PPMd film) that assures an open circuit at the end of life, if the operation is within the specification.

(\*\*) For details please refer to page 10

# Power Electronics Capacitors

## DC CAPACITORS

### DC 86 P Series

Capacitance Cn [ $\mu$ F]	Rated DC Voltage Un [V]	Repet. Peak Voltage Up [kV]	Surge Voltage Us [kV]	Max. RMS Current Imax [A]	Repet. Peak Current Ip [A]	Surge Current Is [kA]	Series Resistance Rs [m $\Omega$ ]	Thermal Resistance R <sub>THC</sub> [°C/W]	Weight [kg]	Terminal solution A / B	Part number 416.86.
15.000	550	0,8	1,3	300	34500	45	< 0,30	0,52	< 19,0	A / B	009.X
11.000	650	1,0	1,5	300	30800	45	< 0,30	0,52	< 19,0	A / B	109.X
8.500	800	1,2	1,8	300	28050	45	< 0,30	0,52	< 19,0	A / B	159.X
5.600	1000	1,5	2,3	250	26880	40	< 0,45	0,52	< 19,0	A / B	209.X
3.800	1200	1,8	2,8	250	22800	40	< 0,50	0,52	< 19,0	A / B	259.X
2.800	1350	2,0	3,1	250	22400	40	< 0,50	0,52	< 19,0	A / B	309.X
2.100	1600	2,4	3,7	200	21000	40	< 0,65	0,52	< 19,0	A / B	359.X
1.700	1800	2,7	4,1	200	20400	40	< 0,70	0,52	< 19,0	A / B	409.X
1.050	2100	3,1	4,8	200	19950	40	< 0,70	0,52	< 19,0	A / B	459.X
650	2700	4,0	6,2	200	19500	35	< 0,75	0,52	< 19,0	A / B	508.X
500	3200	4,8	7,4	200	17500	35	< 0,75	0,52	< 19,0	A / B	559.X
300	3800	5,7	8,7	200	13500	35	< 0,75	0,52	< 19,0	A / B	609.X
200	4500	6,7	10,0	150	13000	30	< 1,20	0,52	< 19,0	A	659.0
160	5200	7,8	10,0	150	11200	30	< 1,20	0,52	< 19,0	A	709.0
120	6000	9,0	10,0	150	10800	25	< 1,40	0,52	< 19,0	A	759.0
80	6800	10,0	10,0	120	9600	20	< 1,50	0,52	< 19,0	A	809.0

- (Cn) Tolerance standard value:  $-15 + 0\%$ . Other tolerance values on request.  
 (Cn) - (Un) Capacitance and rated voltage standard values, other values on request.  
 (Rs) Related to 1 KHz.  
 (R<sub>THC</sub>) Thermal resistance CASE TO AMBIENT in natural cooling environment.  
 (A/B solut.) Due to the clearance distance, B solution (X code = 1) is available only up to Un = 3800 V (Rated Voltage).  
 (X Code) According to terminal type: A solution X = 0 / B solution X = 1.

<b>Box TYPE</b>	
<b>Standard box dimensions</b>	mm 477 x 252 x 172
<b>No. pieces x box:</b>	1

#### INTERNAL CONNECTION:

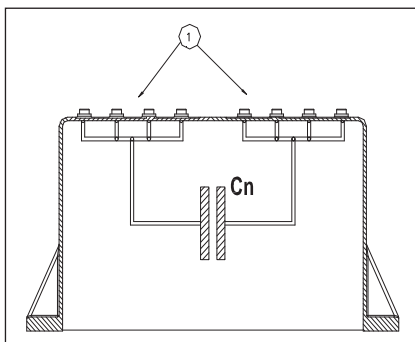

#### ① NOTE:

For A Solution: please, pay attention to connect all of the four M6 internal thread terminals for each polarity.

	A solution (41686.xxx.0)	B solution (41686.xxx.1)
<b>Creepage distance (mm)</b>	100	40
<b>Clearance distance (mm)</b>	93	41

DC CAPACITORS

DC 86 P Series

MECHANICAL SOLUTIONS:

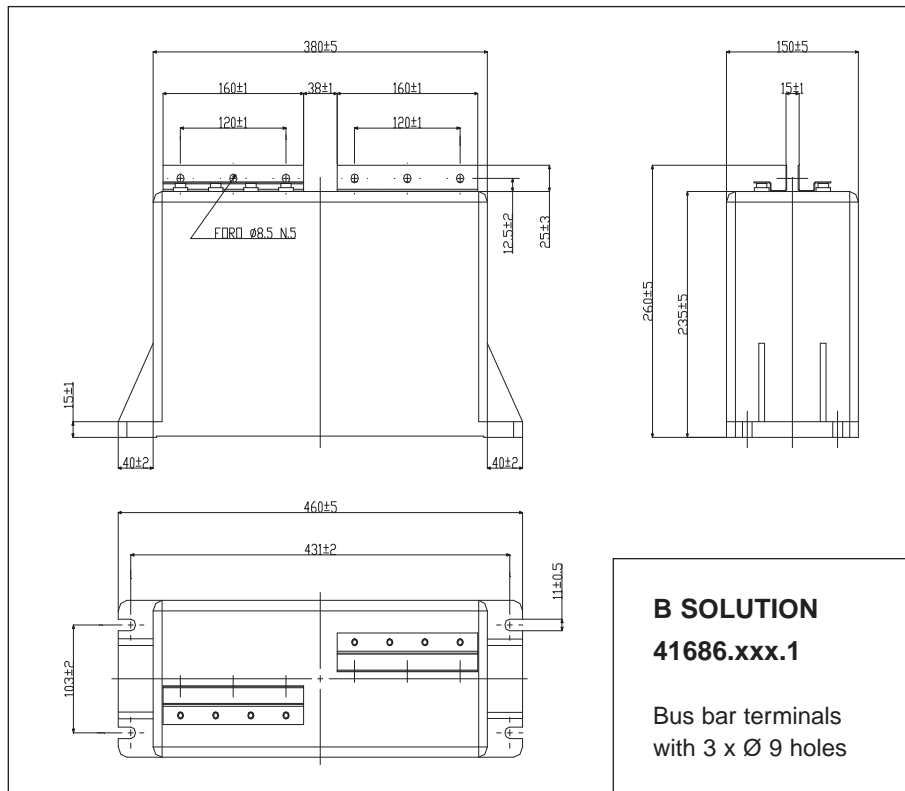
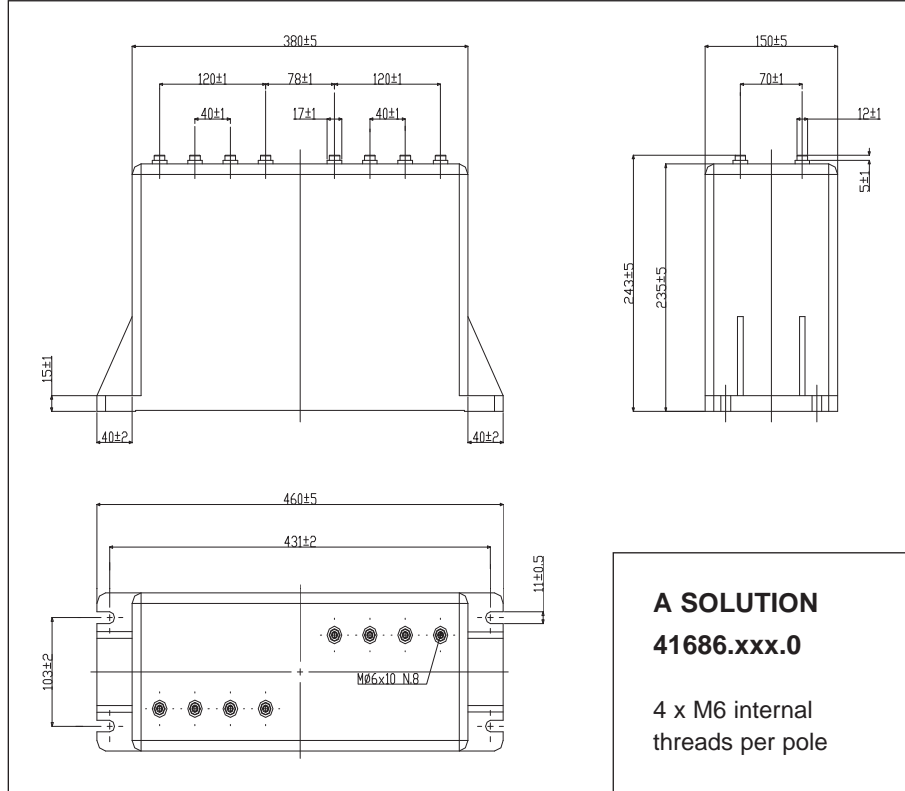

## DC CAPACITORS

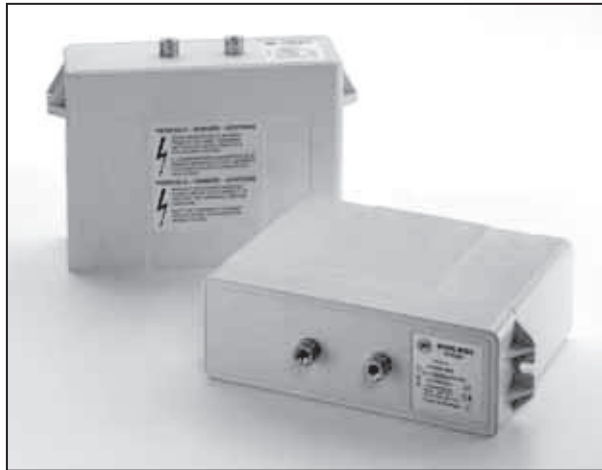

### **DC 86 PS SERIES: Dc - Link Capacitors in box case**

DC Voltage range	550÷2700 V
Maximum ripple current	165 A
Capacitance range	Up to 2100 µF
Capacitance tolerance	±10%
Thermal resistance natural cooling (R <sub>THc</sub> )	2.60 °C/W
Equivalent series inductance (L <sub>ESR</sub> )	< 30 nH
Terminals	M8 x 15 internal threads
Test voltage	U <sub>tc</sub> = 4.5 kVac @50 Hz 60s U <sub>tt</sub> = 1.5 x U <sub>nDC</sub> 10s
Climatic Ambient Temperature	-25 / +45 °C
Working temperature (θ <sub>MIN</sub> – θ <sub>MAX</sub> )	-25 / +85 °C
Storage temperature	-25 / +85 °C
Filling	Self-extinguishing (UL94 V0) polyurethane resin
Dielectric	Self healing PPMd film
Container	Self-extinguishing (UL94 V0) plastic box
Failure quota	50/10E9
Life expectancy	100.000 h (**)
Maximum altitude	2000 m a.s.l.
Reference standard	IEC 1071-1/2 IEC 1881 UL 810
M8 internal thread	Max 4 Nm
Fixing slots	Max 10 Nm
UL-CSA approved (c  )	File n. E192559

**Safety system:** These capacitors are designed with a particular type of polypropylene metalized film (PPMd film) that assures an open circuit at the end of life, if the operation is within the specification.

(\*\*) For details please refer to page 10

# Power Electronics Capacitors

## DC CAPACITORS

### DC 86 PS Series

Capacitance Cn [ $\mu$ F]	Rated DC Voltage Un [V]	Repet. Peak Voltage Up [kV]	Surge Voltage Us [kV]	Max. RMS Current I <sub>MAX</sub> [A]	Repet. Peak Current Ip [A]	Surge Current Is [kA]	Series Resistance Rs [m $\Omega$ ]	Thermal Resistance R <sub>THS</sub> [ $^{\circ}$ C/W]	Weight [kg]	Part number 416.86.xxxx
2.100	550	0,8	1,2	165	16.800	29,5	< 0,48	2,60	< 4,5	0095
1.500	700	1,0	1,5	165	15.000	28,0	< 0,50	2,60	< 4,5	1095
1.150	850	1,3	1,8	155	13.800	26,0	< 0,55	2,60	< 4,5	1595
750	1100	1,7	2,3	150	12.000	25,0	< 0,59	2,60	< 4,5	2095
600	1250	1,9	2,6	140	11.400	23,0	< 0,66	2,60	< 4,5	2595
500	1400	2,1	2,9	130	11.000	21,5	< 0,73	2,60	< 4,5	3095
380	1600	2,4	3,4	120	10.640	20,5	< 0,85	2,60	< 4,5	3595
300	1800	2,7	3,8	120	10.500	19,0	< 0,89	2,60	< 4,5	4095
230	2100	3,2	4,4	110	9.660	18,5	< 0,98	2,60	< 4,5	4595
120	2700	4,1	5,7	100	7.800	14,5	< 1,15	2,60	< 4,5	5095

**NOTES:**

- (Cn) Tolerance standard value:  $\pm 10\%$ . Other tolerance values on request.
- (Cn) - (Un) Capacitance and rated voltage standard values, other values on request.
- (Rs) Related at 1 KHz.
- (R<sub>THS</sub>) Thermal resistance AMBIENT - HOT SPOT (air forced cooling system).
- (I<sub>MAX</sub>) Maximum RMS Current @ 50  $^{\circ}$ C ambient temperature.

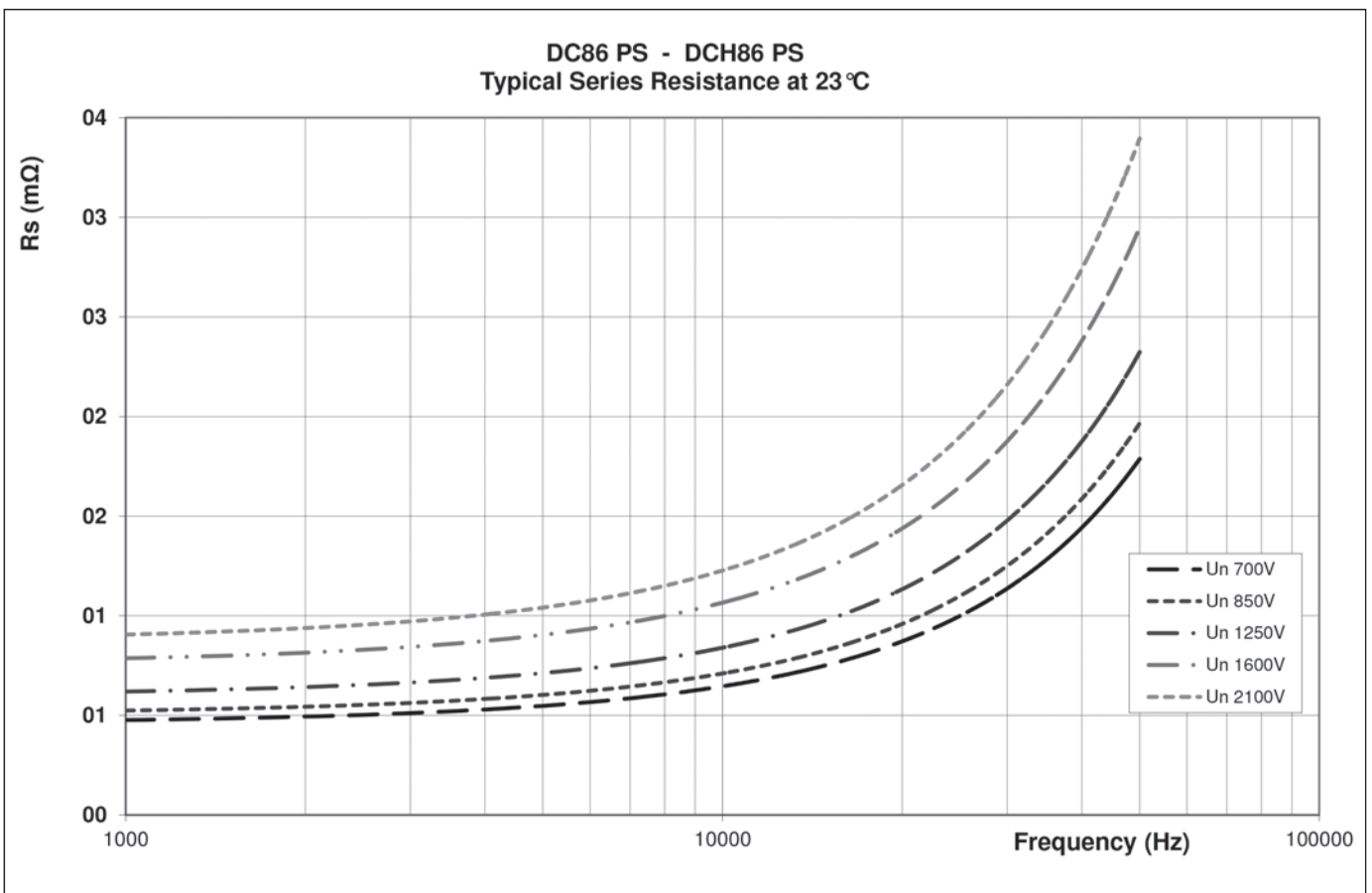

# Power Electronics Capacitors

## DC CAPACITORS

### MECHANICAL SOLUTION:

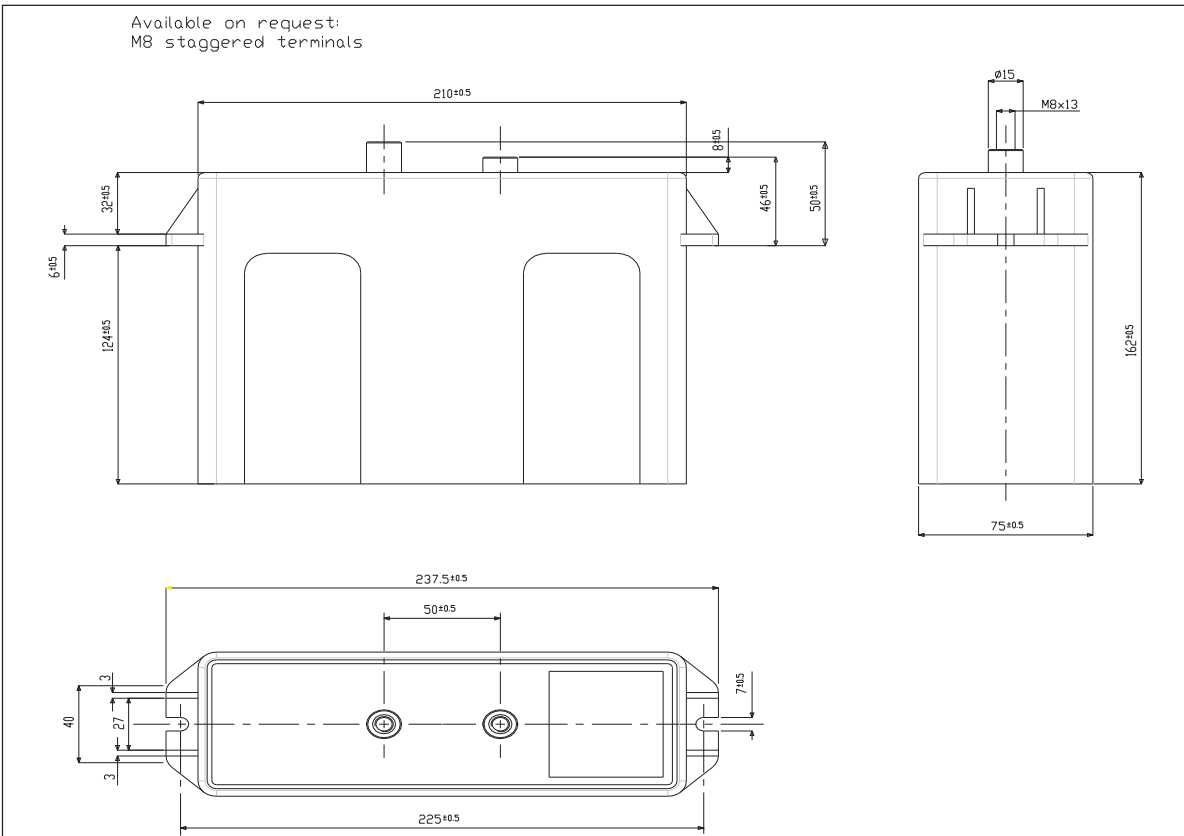
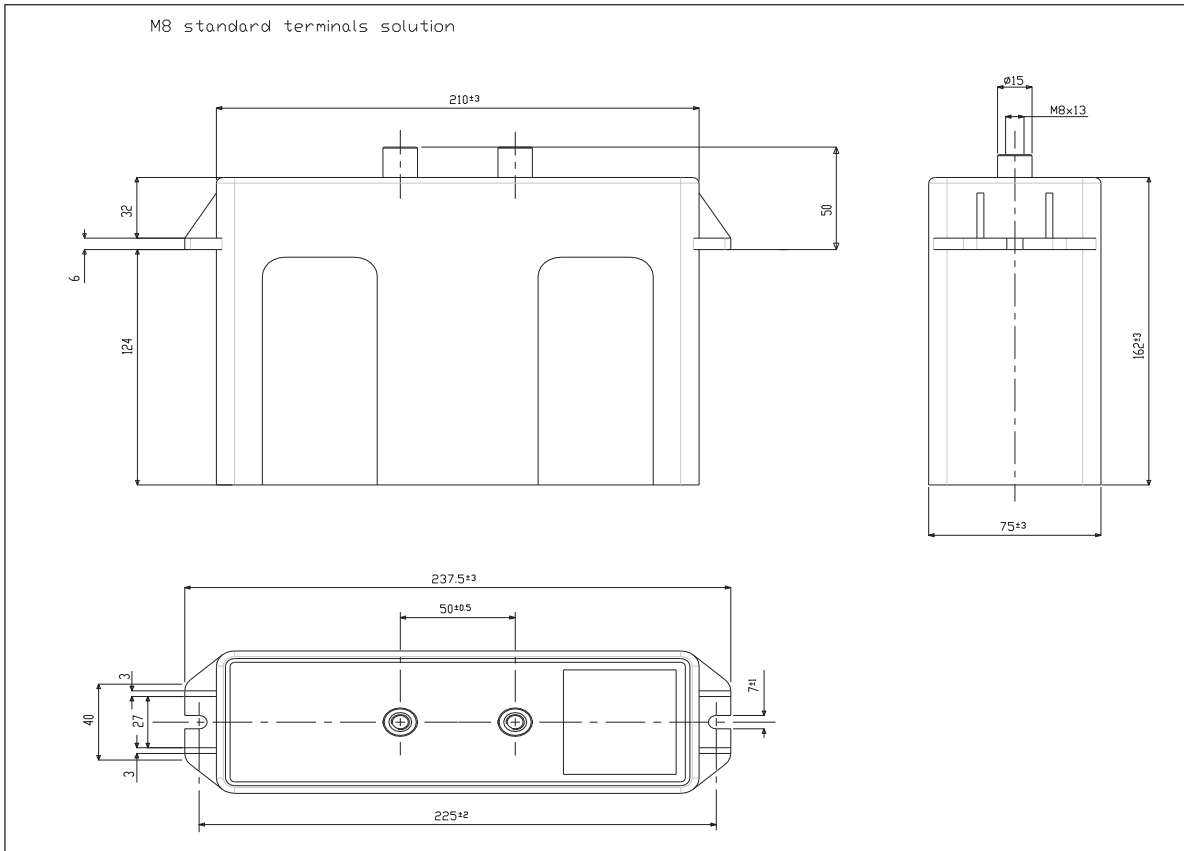

Creepage distance (mm)	35
Clearance distance (mm)	35

#### Box TYPE

Standard box dimensions:  
No. pieces per box:

mm 450 x 470 x 220  
8

## DC CAPACITORS



**DC 89 HC SERIES: High current, low inductance in cylindrical plastic case, optimised for heatsink mounting**

DC Voltage range	500÷1450 V(*)
Maximum ripple current	100 A
Maximum working frequency	10 kHz
Capacitance range	Up to 220 µF (*)
Capacitance tolerance	±10% (*)
Terminals	M8 screw-type bolts ur female M5
Test voltage	U <sub>tc</sub> = 3,0 kVac @50 Hz 60s U <sub>tt</sub> = 1,5 x U <sub>nDC</sub> 10s
Climatic Ambient Temperature	-25 / +45 °C
Working temperature (θ <sub>MIN</sub> – θ <sub>MAX</sub> )	-25 / +85 °C
Storage temperature	-25 / +85 °C
Filling	Polyurethane resin
Dielectric	Self healing PPM film
Container	Self-extinguishing (UL94 V0) plastic box
Failure quota	50/10E9
Life expectancy	100.000 h(**)
Maximum altitude	2000 m a.s.l.
Reference standard	IEC 1071-1/2 IEC 1881 UL 810
Driving torque for M8 screw-type	5 Nm
Driving torque for fixing holes (MAX)	2,5 Nm
Standard Box dimension	386 x 190 x 200 mm
Number pieces for box	16
M8 screw terminals	Max 5 Nm
Fixing slots	Max 2,5 Nm
UL - CSA approved (UL  )	File n. E192559

(\*\*) For details please refer to page 10



# Power Electronics Capacitors

## DC CAPACITORS

### DC 89 HC Series

Capacitance Cn [µF]	Height H [mm]	Repet. Peak Voltage Up [kV]	Max. RMS Current I <sub>MAX</sub> [A]	Repet. Peak Current Ip [A]	Surge Current Is [kA]	Series Resistance R <sub>ESR</sub> [mΩ]	Thermal Resistance R <sub>THC</sub> [°C/W]	Series Inductance L <sub>ESR</sub> [nH]	Weight [kg]	Part number 416.89.
<b>Un<sub>DC</sub> = 500 V</b>					<b>Us = 1,0 kV</b>					
70	40	0,75	100	9000	13,0	0,55	4,8	< 25	< 0,45	051X
100	40	0,75	100	8500	12,7	0,60	4,8	< 25	< 0,45	052X
130	51	0,75	85	8000	11,5	0,70	5,7	< 30	< 0,55	053X
160	51	0,75	85	7000	10,5	0,75	5,7	< 30	< 0,55	055X
190	64	0,75	70	6500	10,0	0,78	7,8	< 40	< 0,70	057X
220	64	0,75	70	6200	9,3	0,80	7,8	< 40	< 0,65	059X
<b>Un<sub>DC</sub> = 700 V</b>					<b>Us = 1,4 kV</b>					
60	40	1,05	90	8000	12,0	0,70	4,8	< 25	< 0,45	071X
80	40	1,05	90	7500	11,3	0,75	4,8	< 25	< 0,45	072X
100	51	1,05	80	7400	11,0	0,80	5,7	< 30	< 0,55	072X
130	51	1,05	80	7200	10,8	0,85	5,7	< 30	< 0,55	075X
150	64	1,05	65	6400	10,5	0,87	7,8	< 40	< 0,70	075X
180	64	1,05	65	6600	9,9	0,90	7,8	< 40	< 0,65	079X
<b>Un<sub>DC</sub> = 900 V</b>					<b>Us = 1,8 kV</b>					
45	40	1,35	85	5300	8,0	0,80	4,8	< 25	< 0,45	091X
70	40	1,35	85	5250	7,8	0,85	4,8	< 25	< 0,45	092X
100	51	1,35	75	4700	7,5	0,95	5,7	< 30	< 0,55	095X
110	51	1,35	75	4650	7,3	0,98	5,7	< 30	< 0,55	096X
125	64	1,35	60	4600	7,0	1,00	7,8	< 40	< 0,70	097X
150	64	1,35	60	4500	6,8	1,10	7,8	< 40	< 0,65	099X
<b>Un<sub>DC</sub> = 1100 V</b>					<b>Us = 2,2 kV</b>					
30	40	1,65	80	4800	7,8	0,90	4,8	< 25	< 0,45	111X
45	40	1,65	80	4750	7,2	0,95	4,8	< 25	< 0,45	112X
70	51	1,65	65	4600	7,0	1,00	5,7	< 30	< 0,55	114X
75	51	1,65	65	4550	6,8	1,10	5,7	< 30	< 0,55	115X
100	64	1,65	55	4500	6,7	1,20	7,8	< 40	< 0,70	118X
110	64	1,65	55	4400	6,6	1,25	7,8	< 40	< 0,65	119X
<b>Un<sub>DC</sub> = 1250 V</b>					<b>Us = 2,5 kV</b>					
20	40	1,90	75	4500	6,8	1,15	4,8	< 25	< 0,45	121X
35	40	1,90	75	4200	6,6	1,20	4,8	< 25	< 0,45	122X
45	51	1,90	65	4200	6,4	1,25	5,7	< 30	< 0,55	123X
55	51	1,90	65	4200	6,2	1,30	5,7	< 30	< 0,55	125X
70	64	1,90	55	4000	6,0	1,35	7,8	< 40	< 0,70	127X
80	64	1,90	55	4000	6,0	1,40	7,8	< 40	< 0,65	129X
<b>Un<sub>DC</sub> = 1450 V</b>					<b>Us = 2,9 kV</b>					
15	40	2,20	70	3500	5,2	1,25	4,8	< 25	< 0,45	141X
25	40	2,20	70	3380	5,1	1,30	4,8	< 25	< 0,45	142X
30	51	2,20	60	3200	4,8	1,45	5,7	< 30	< 0,55	143X
40	51	2,20	60	3200	4,8	1,45	5,7	< 30	< 0,55	145X
50	64	2,20	50	3100	4,6	1,50	7,8	< 40	< 0,70	147X
55	64	2,20	50	3050	4,5	1,55	7,8	< 40	< 0,65	149X

- (Cn) Tolerance standard value: ±10%. Other tolerance values on request.
- (Cn) - (Un) Capacitance and rated voltage standard values, other values on request.
- (Rs) Related to 1KHz.
- (R<sub>THC</sub>) Thermal resistance CASE TO AMBIENT in natural cooling environment. In order to decrease the thermal resistance, install the capacitors on a heatsink (with conductive paste) through the optimised bottom aluminum plate.
- (I<sub>MAX</sub>) Maximum RMS current, referred to an ambient temperature of 50 °C, natural cooling.  
In case of different temperature, see diagram at page ....
- (X) Code According to mechanical solution: from Ø to 4 for M8 screw type bolt, from 5 to 8, for female M5 internal threads.

# Power Electronics Capacitors

## DC CAPACITORS

### DC 89 HC Series

<b>Box TYPE</b>	
<b>Standard box dimensions</b>	mm 386 x 190 x 200
<b>No. pieces x box:</b>	16

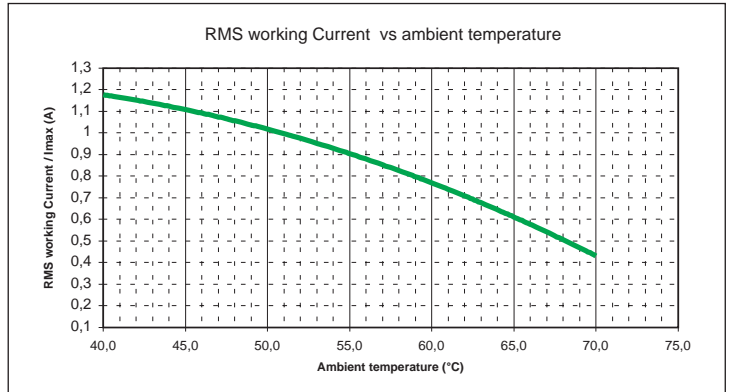

### MECHANICAL SOLUTIONS:

**Type A: MALE M8 SCREW TYPE BOLT**

**Solutions:**

- H = 40 ± 2 mm
- H = 51 ± 2 mm
- H = 64 ± 2 mm

<b>Creepage distance (mm)</b>	<b>37</b>
<b>Clearance distance (mm)</b>	<b>27</b>

# Power Electronics Capacitors

## DC CAPACITORS

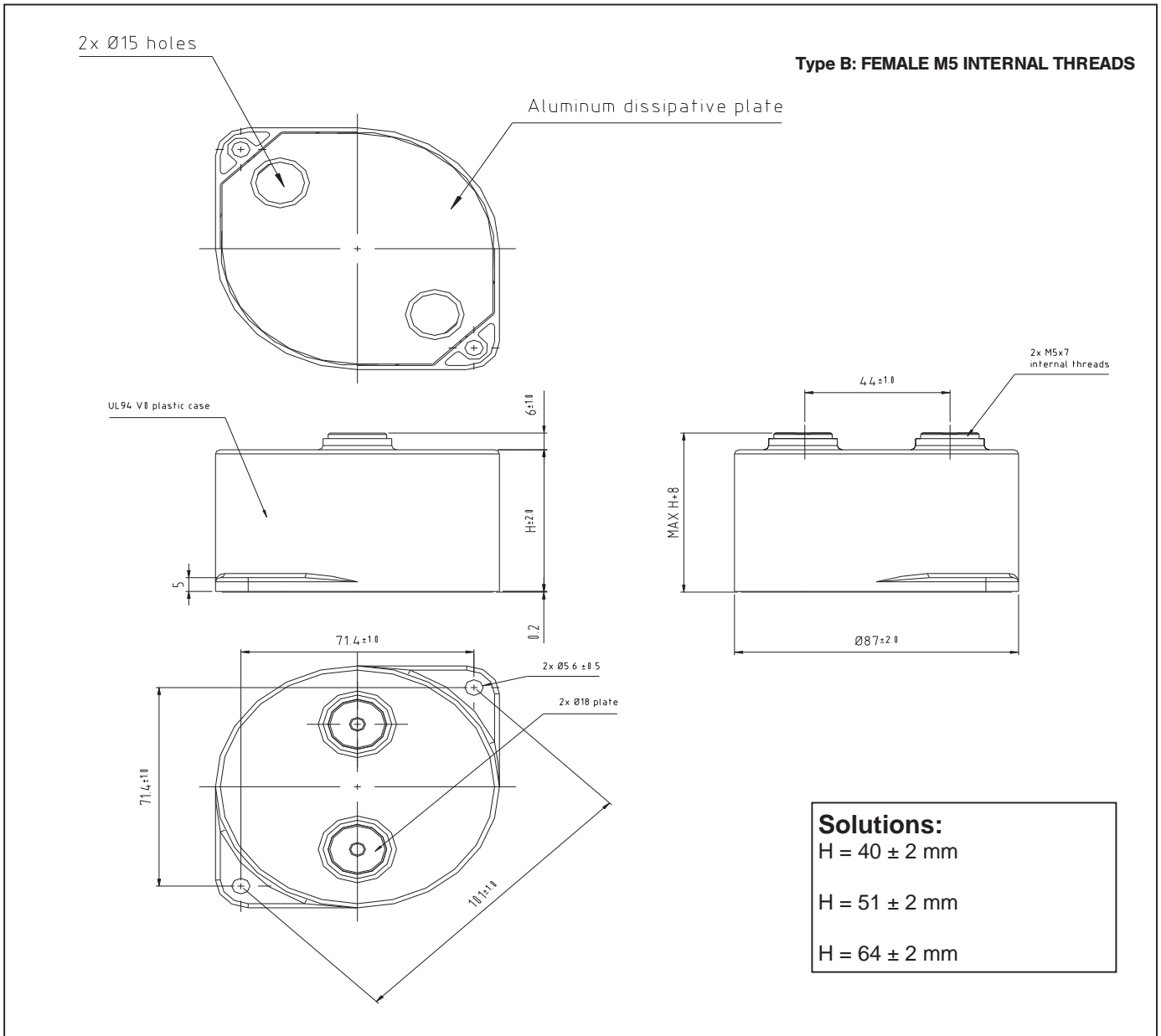

(x) digit: from 6 to 9 for M5 internal threads configuration

Creepage distance (mm)	37
Clearance distance (mm)	27

## DC CAPACITORS

TYPICAL Serie Resistance for DC89HC

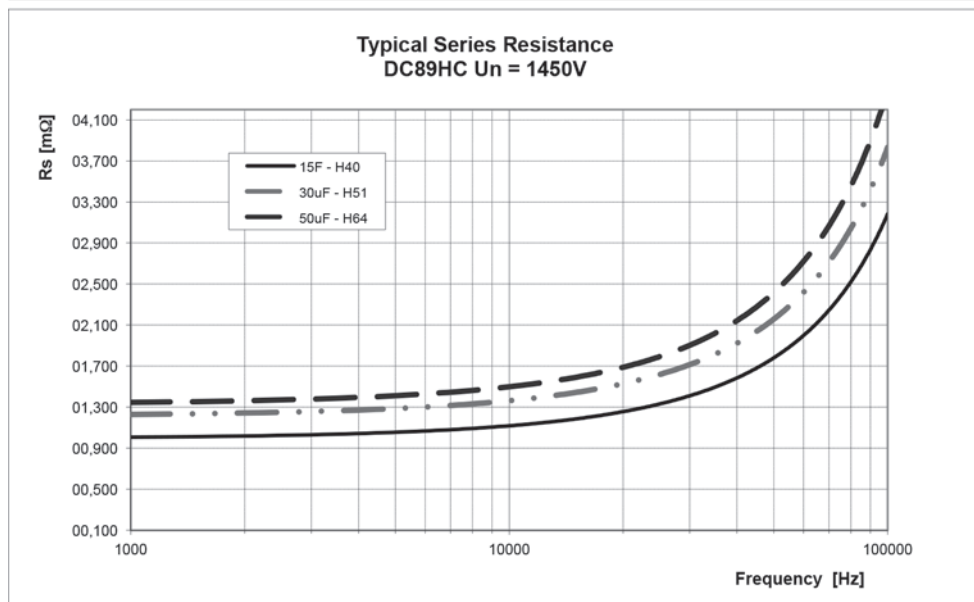
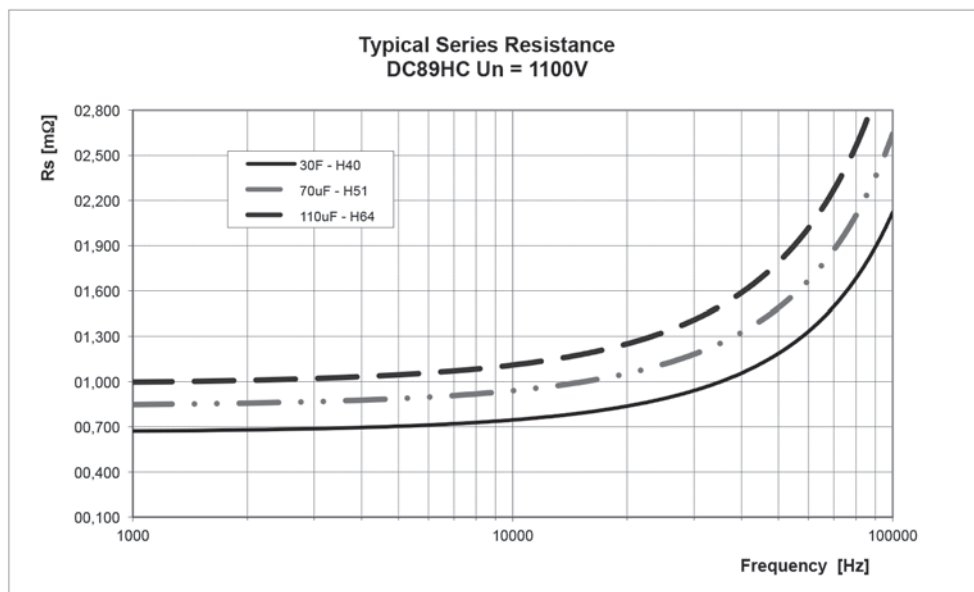
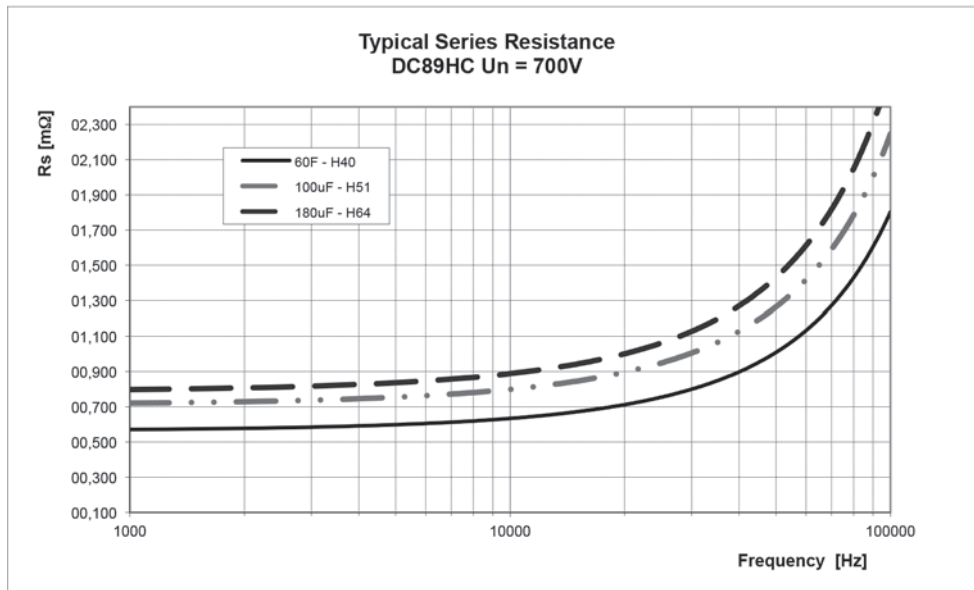



# Power Electronics Capacitors

## DC CAPACITORS

### **DC 88 M SERIES: standard model** **Dc - Link Capacitors in stainless steel, non-magnetic casing**

**DC-Link Capacitors, resin filled in prism metal case**  
**Capacitor specifically designed for high working current, low inductance and optimised on customer request.**

#### TYPICAL APPLICATIONS:

DC filtering or DC LINK capacitor for INVERTER with terminals suited for a direct connection to the IGBT module terminals or bus-bars.

#### FEATURES:

The aluminum or steel box is hermetically sealed by a polyurethane resin that assure a total protection against the environment and also allows use of different terminal types. The internal metallized polypropylene film assures excellent self healing properties, moreover the special internal connection between elements gives low series inductance.



DC Voltage range	550÷1550 V(*)
Maximum ripple current	300 A
Capacitance range	Up to 10500 µF
Capacitance tolerance	±10%
Equivalent series inductance (L <sub>ESR</sub> )	35 nH to 50 nH
Terminals	4x M10 screw type Its
Test voltage	U <sub>tc</sub> = 4.5 kVac @50 Hz 60s U <sub>tt</sub> = 1.5 x U <sub>nDC</sub> 10s
Climatic Ambient Temperature	-25 / +45 °C
Working temperature (θ <sub>MIN</sub> – θ <sub>MAX</sub> )	-25 / +85 °C
Storage temperature	-25 / +85 °C
Filling	Polyurethane resin
Dielectric	Self healing PPMd film
Container	Non painted, stainless steel, not magnetic casing
Failure quota	50/10E9
Life expectancy	100.000 h (**)
Maximum altitude	2000 m a.s.l.
Reference standard	IEC 1071-1/2 IEC 1881
M10 internal thread	Max 6 Nm
Fixing slots	Max 15 Nm

**Safety system:** These capacitors are designed with a particular type of polypropylene metallized film (PPMd film) that assures an open circuit at the end of life, if the operation is within the specification.

(\*\*) For details please refer to page 10

# Power Electronics Capacitors

## DC CAPACITORS

### DC 88 M Series

Capacitance Cn [μF]	Height H [mm]	Width W [mm]	Max. RMS Current I <sub>MAX</sub> [A]	Repet. Peak Current Ip [kA]	Surge Current Is [kA]	Series Resistance Rs [mΩ]	Thermal Resistance R <sub>THC</sub> [°C/W]	Inductance Ls [nH]	Typical Weight [kg]	Part number 416.88.
<b>Un<sub>DC</sub> = 550 V</b>			<b>Up = 8,5 kV</b>			<b>Us = 1,3 kV</b>				
3.200	170	95	180	22,4	36	< 0,80	1,25	35	< 10,5	1091
5.000	240	95	300	25,0	40	< 0,40	0,85	45	< 13,0	1192
5.500	170	145	170	24,8	40	< 0,85	1,35	40	< 14,5	1293
8.500	240	145	230	25,5	41	< 0,50	1,15	50	< 18,5	1394
6.650	170	170	150	21,3	34	< 1,05	1,35	45	< 16,0	1495
10.500	240	170	230	26,3	42	< 0,65	0,95	50	< 21,5	1596
<b>Un<sub>DC</sub> = 700 V</b>			<b>Up = 1,05 kV</b>			<b>Us = 1,6 kV</b>				
2.400	170	95	180	19,2	31	< 0,85	1,25	35	< 10,5	2091
3.800	240	95	300	22,8	36	< 0,45	0,85	45	< 13,0	2192
4.250	170	145	170	23,4	37	< 0,85	1,35	40	< 14,5	2293
6.500	240	145	220	22,8	36	< 0,60	1,15	50	< 18,5	2394
5.000	170	170	150	20,5	33	< 1,10	1,35	45	< 16,0	2495
8.000	240	170	230	24,8	40	< 0,65	0,95	50	< 21,5	2596
<b>Un<sub>DC</sub> = 1000 V</b>			<b>Up = 1,4 kV</b>			<b>Us = 2,3 kV</b>				
1.600	170	95	180	19,2	31	< 0,85	1,25	35	< 10,5	3091
2.530	240	95	300	20,2	32	< 0,45	0,85	45	< 13,0	3192
2.650	170	145	170	18,6	30	< 0,85	1,35	40	< 14,5	3293
4.300	240	145	220	21,5	34	< 0,60	1,15	50	< 18,5	3394
3.250	170	170	150	16,3	26	< 1,10	1,35	45	< 16,0	3495
5.060	240	170	230	20,2	32	< 0,65	0,95	50	< 21,5	3596
<b>Un<sub>DC</sub> = 1200 V</b>			<b>Up = 1,7 kV</b>			<b>Us = 2,4 kV</b>				
1.100	170	95	170	22,0	35	< 0,90	1,25	35	< 10,5	4091
1.750	240	95	280	19,3	31	< 0,50	0,85	45	< 13,0	4192
1.900	170	145	160	19,0	30	< 1,00	1,35	40	< 14,5	4293
3.000	240	145	250	21,0	34	< 0,55	1,15	50	< 18,5	4394
2.250	170	170	140	19,1	31	< 1,25	1,35	45	< 16,0	4495
3.700	240	170	240	20,4	33	< 0,65	0,95	50	< 21,5	4596
<b>Un<sub>DC</sub> = 1350 V</b>			<b>Up = 1,9 kV</b>			<b>Us = 2,4 kV</b>				
750	170	95	160	21,0	34	< 1,10	1,25	35	< 10,5	5091
1.300	240	95	270	18,2	29	< 0,55	0,85	45	< 13,0	5192
1.350	170	145	150	20,3	32	< 1,15	1,35	40	< 14,5	5293
2.200	240	145	250	22,0	35	< 0,55	1,15	50	< 18,5	5394
1.650	170	170	130	19,8	32	< 1,45	1,35	45	< 16,0	5495
2.700	240	170	230	21,6	35	< 0,70	0,95	50	< 21,5	5596
<b>Un<sub>DC</sub> = 1550 V</b>			<b>Up = 2,1 kV</b>			<b>Us = 2,4 kV</b>				
550	170	95	150	18,7	30	< 1,15	1,25	35	< 10,5	6091
900	240	95	240	18,0	29	< 0,65	0,85	45	< 13,0	6192
1.000	170	145	140	22,0	35	< 1,20	1,35	40	< 14,5	6293
1.600	240	145	230	19,2	31	< 0,60	1,15	50	< 18,5	6394
1.200	170	170	120	21,6	35	< 1,60	1,35	45	< 16,0	6495
2.000	240	170	220	20,0	32	< 0,75	0,95	50	< 21,5	6596

- (Cn) Tolerance standard value: ±10%. Other tolerance values on request.  
(Cn) - (Un) Capacitance and rated voltage standard values, other values on request.  
(Rs) Releated at 1 KHz.  
(R<sub>THC</sub>) Thermal resistance AMBIENT - CASE.  
(I<sub>MAX</sub>) Maximum RMS Current @ 45 °C ambient temperature.  
(Ls) Standard stray inductance. On request very low stray inductance models.

### DC 88 M Series

#### MECHANICAL SOLUTIONS:

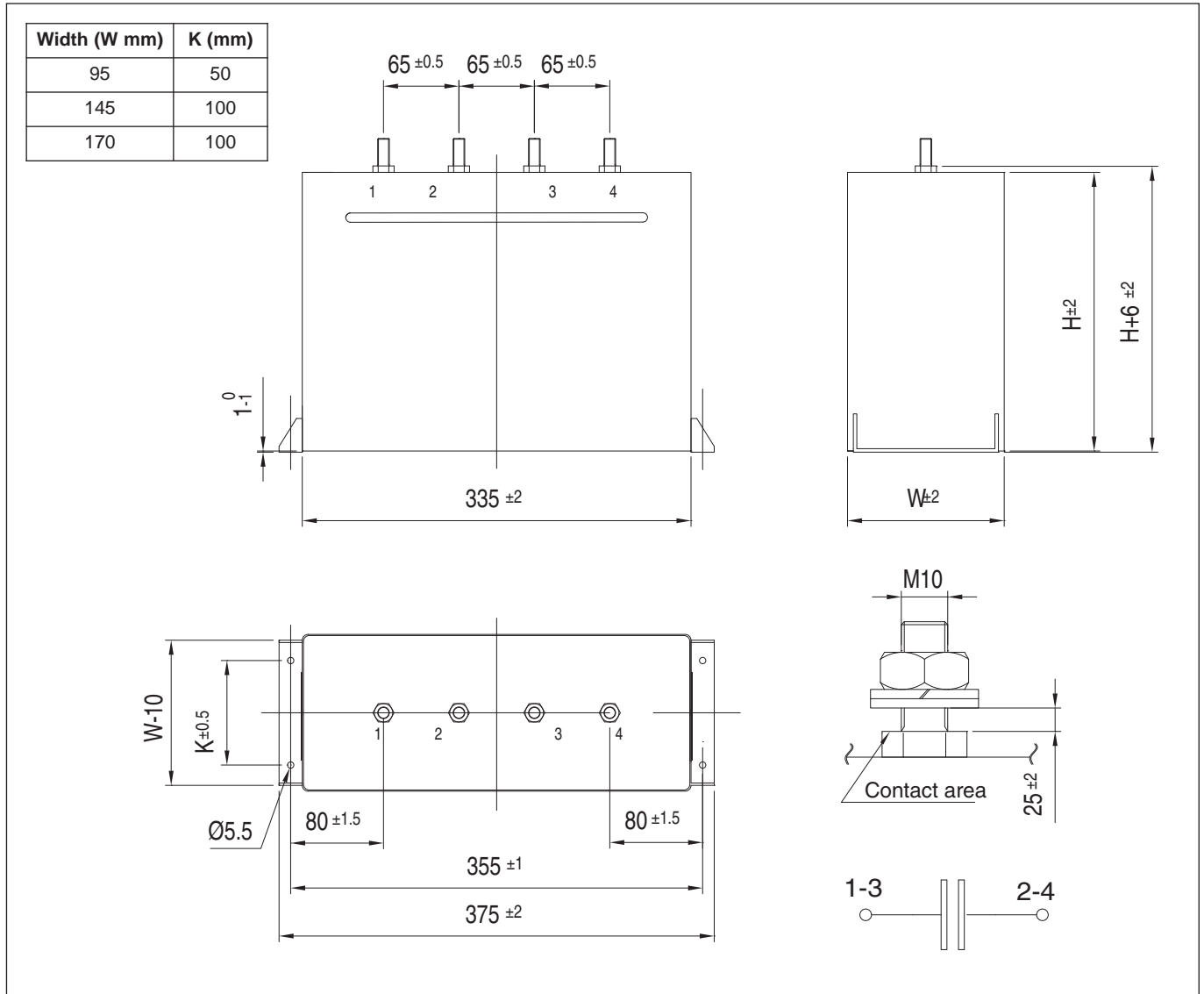

#### Safety system:

This capacitors are designed with a particular type of polypropylene metalized film (PPM-D film) that assures an open circuit at the end of life, if the service is within the specification.

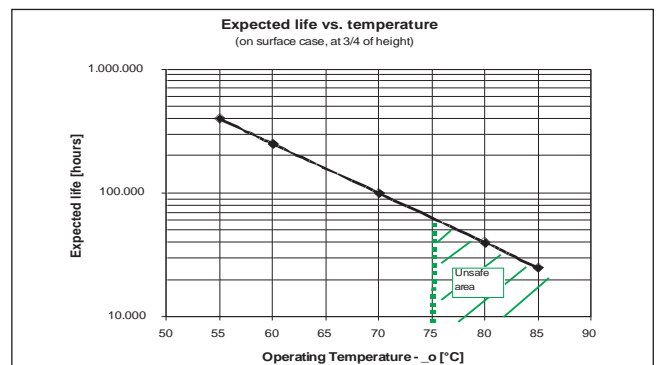
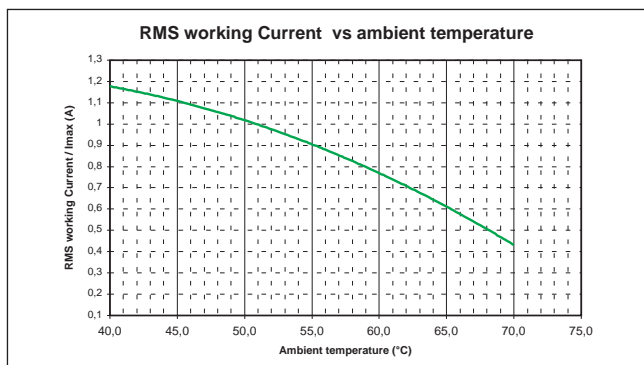



# Power Electronics Capacitors

## DC CAPACITORS

### DC 88 M Series

CUSTOMIZED MECHANICAL AND TERMINAL SOLUTIONS

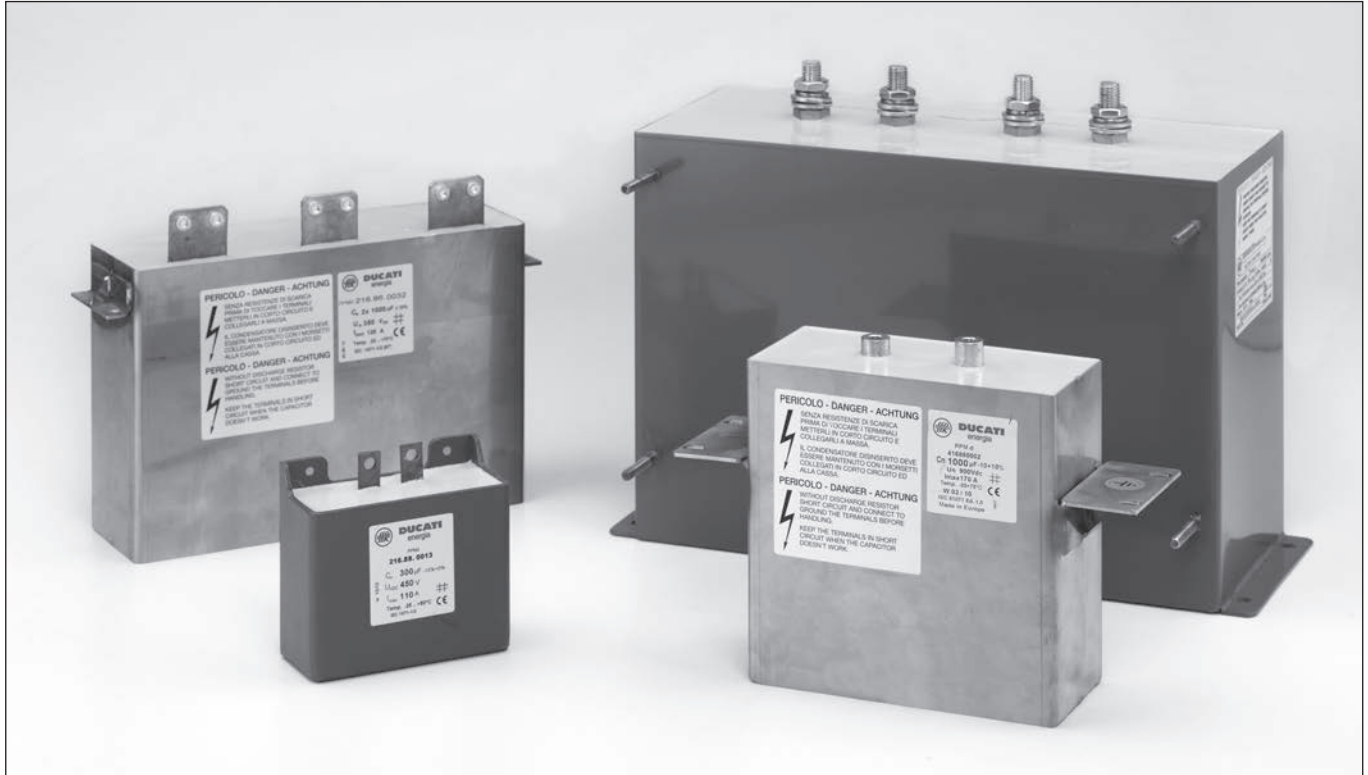

### ELECTRICAL AND MECHANICAL CHARACTERISTICS

		Examples			
Capacitance	Cn [ $\mu$ F]	1000	3000	1000	2x 3000
Rated DC Voltage	Un [V]	900	1200	500	700
Repet. Peak Voltage	Up [kV]	1250	1700	750	1050
Surge Voltage	Us [kV]	1900	2500	1000	1500
Max. RMS Current	I <sub>MAX</sub> [A]	170	300	150	2x 230
Repet. Peak Current	I <sub>p</sub> [A]	9000	22000	15000	20000
Surge Current	I <sub>s</sub> [kA]	15	35	25	30
Series Resistance	Rs [m $\Omega$ ]	< 2,0	< 1,0	< 3,0	< 1,5
Series Inductance	L <sub>ESR</sub> [nH]	< 45 nH	< 50 nH	< 30 nH	< 80 nH
Dimensions	L x W x H (mm)	165 x 75 x 170	340 x 145 x 240	172 x 105 x 94	440 x 100 x 270



# Power Electronics Capacitors

## DC CAPACITORS

### DC 45 SERIES

Capacitors for filtering in locomotive, traction applications and welding machine by capacitance discharge with high capacitance and high voltage

#### FEATURES

- Steel or aluminum case
- Impregnated
- Screw type bolts
- DC voltage

#### TYPICAL APPLICATIONS

- Traction filtering
- Welding machines

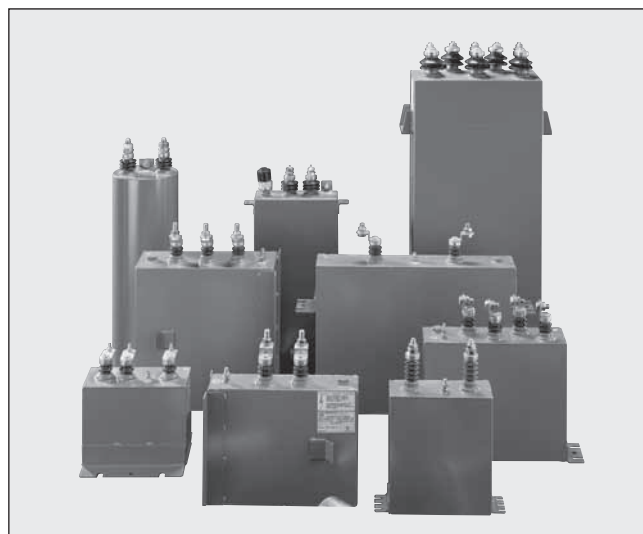

<i>GENERAL CHARACTERISTICS</i>	
DC Voltage range	800÷5000V (*)
Capacitance range	100÷5000 µF (*)
Capacitance tolerance	±5% / ±10%
Test voltage between terminals	1,5 Un 10s
Test voltage between terminals and case	2 Un 50 Hz 60s
Terminals	Bushings
Ambient operating temperature	-25 / + 55 °C
Protection degree	IP 00
Filling	Castor oil
Dielectric	Mosaic metallized polypropylene
Case	Steel
Life expectancy	100.000 h (**)
Installation	Vertical / horizontal
Reference standard	IEC 1071-1/2; IEC 1881; UL 810

(\*) Standard values, other values on request.

(\*\*) For details please refer to page 10

## DC CAPACITORS

### Example of filter capacitor:

#### CHARACTERISTICS

Rated Capacitance	1000 $\mu$ F
Capacitance Tolerance	$\pm 10$ %
Rated Voltage $U_n$ (DC)	3500 V
Rated Current ( $I_n$ )	300 A
Serial Inductance	$\sim 300$ nH
Tan $\delta$	$\sim 25 \cdot 10^{-4}$ (50 Hz, 20 °C)

#### MAXIMUM RATINGS

Max Voltage	3600 V
Max Peak Current	5 kA
(du/dt) <sub>max</sub>	5 V/ $\mu$ s
Max Duty Cycle	1 discharge/1sec

#### TEST DATA

AC Test voltage terminal to terminal	5 kVac (2 sec)
AC test voltage terminal to case	7 kVac (50 Hz - 60 sec)

#### CLIMATIC CATEGORY

Operating Temperature	- 25 / + 55 °C
-----------------------	----------------

#### MECHANICAL CHARACTERISTICS

Dimensions	175 x 330 x 570 mm
Weight	<45 Kg
Case	Stainless steel
Painted case	
With Overpressure device	
Without discharge resistor	

#### TERMINALS AND INSULATION

Terminal	Z type
Material	Ceramic
Creepage distance	40 mm
Clearance	31 mm
Expected life	100000 h
Impregnation	Non polluting oil (NO PCB)

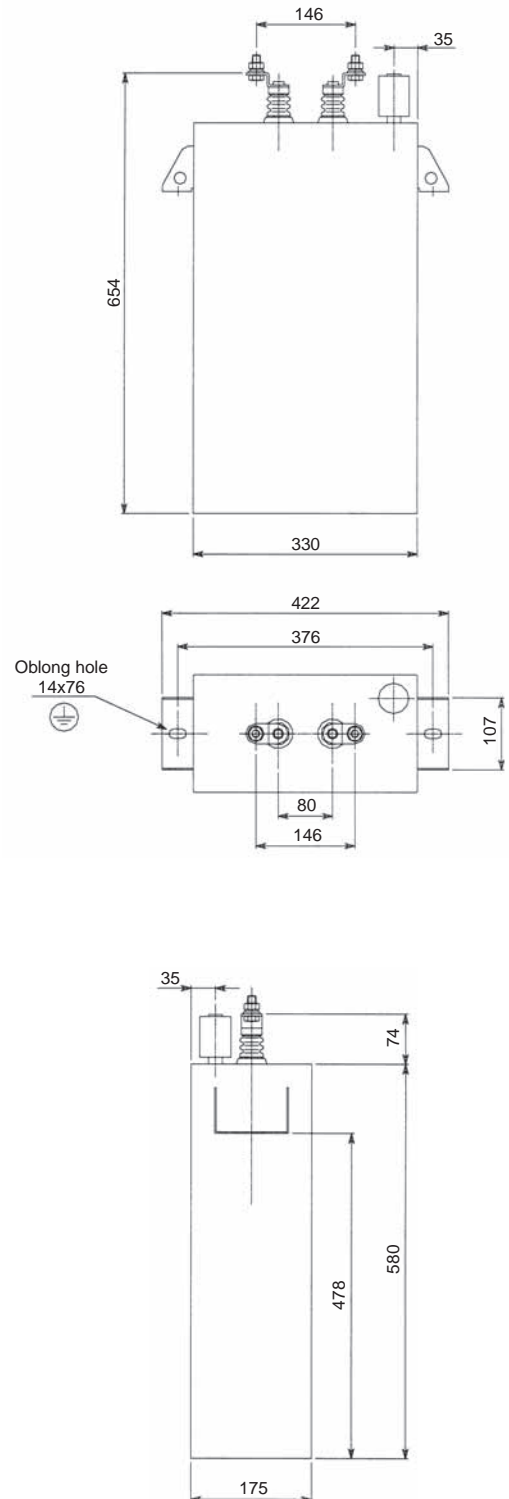



## Power Electronics Capacitors

# INQUIRY FORM

In case of custom design, or for any special request / quotation, please complete the following form.

<b>Company Name</b> _____
<b>Contact Person</b> _____
<b>Phone / Fax / E-mail</b> _____

<b>Application</b> _____
--------------------------

### Technical characteristics

Value	Unit	Condition / Time / Note
<b>CAPACITANCE</b>		
<b>Rated Capacitance</b>	μF	
Capacitance Tolerance	%	
<b>VOLTAGE</b>		
<b>Rated AC Voltage (Urms)</b>	V	
<b>Rated DC Voltage (Un)</b>	V	
Superimposed ripple voltage (Ur)	Vpp	
<b>Frequency of ripple voltage (fr)</b>	Hz	
<b>Maximum recurrent peak voltage</b>	V	
<b>Maximum surge voltage (Us)</b>	V	
Voltage raise of rise (dV/dT)	V/μs	
<b>CURRENT</b>		
Rated rms current	A	
<b>Maximum rms Current @ θ MAX (I<sub>MAX</sub>)</b>	A	
<b>Maximum peak current (Is)</b>	kA	
<b>OPERATING DATA</b>		
Maximum permissible inductance	nH	
Maximum series resistance (RS)	mΩ	
Maximum tan δ (10E <sup>-4</sup> ) @ 50 Hz		
Min.operating temperature (θ MIN)	°C	
<b>Max. operating temperature (θ MAX)</b>	°C	
Storage temperature MIN / MAX	°C	
Altitude maximum	m	
Expected life timehours		
<b>MECHANICAL REQUIREMENTS</b>		
<b>Maximum dimensions (WxLxH)</b>	mm	
Flash over distance	mm	
Creepage distance	mm	
<b>Terminals</b>		
<b>FURTHER REQUIREMENTS</b>		
Quantity	pcs/year	
Start of delivery		

(\*) Bold type: fundamental parameters



# Power Electronics Capacitors

## INQUIRY FORM

Circuit scheme														

Current and voltage waveforms														

PLEASE COPY, COMPLETE AND RETURN TO:



Via M.E. Lepido, 182 - 40132 Bologna - Italy  
Tel. +39 051 6411511 - Fax. +39 051 402040  
www.ducatienergia.com - E-mail: commri@ducatienergia.com

## Notes



# CAPACITORS / PFC PRODUCT RANGE



## Low Voltage Power Factor Correction

- *Capacitors*
- *Components*
- *Power Factor Correction Equipments*
- *Static / Real-Time PFC Equipments*
- *Active Harmonic Filters*



## Medium / High Voltage Power Factor Correction

- *Capacitors*
- *Components*
- *Outdoor / Indoor Rack-Type PFC Equipment*
- *Outdoor / Indoor Metal-Clad PFC Equipment*
- *Passive Harmonic Filters*



## Power / Energy Analysers and Measurement Instruments

- *Panel Mounted Power / Energy Analysers*
- *DIN-rail Power / Energy Analysers*
- *Energy Monitoring Networks & Accessories*
- *Energy Monitoring Software*

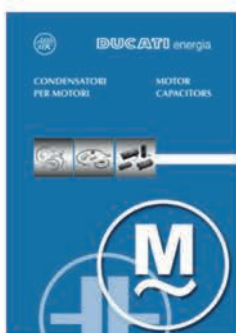

## Motor-Run / Motor-Start Capacitors

- *Plastic Case P0 / S0 Capacitors*
- *Plastic Case P2 / S3 Capacitors*
- *Plastic Case P0 / S0 Capacitors with Disconnectors*
- *Aluminum Case P2 / S2 Capacitors*
- *Electrolytic Motor-Start Capacitors*
- *Assembled Motor-Start/Run Boxes*

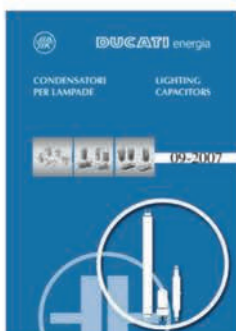

## Lighting Capacitors

- *Plastic Case Type-A Capacitors*
- *Aluminum Case Type-B Capacitors*
- *Aluminum Case Type-B, Heavy-Duty Capacitors*



# DUCATI energia

HISTORY DRIVES THE FUTURE

Via M. E. Lepido, 182 - 40132 Bologna - Italy  
Tel. +39 051 6411511 - Fax +39 051 402040  
[www.ducatienergia.com](http://www.ducatienergia.com) - E-mail: [commri@ducatienergia.com](mailto:commri@ducatienergia.com)

Per la continua evoluzione della nostra tecnologia, ci riserviamo il diritto di cambiare le suddette specifiche senza preavviso.  
Due to the continual development of our technology, we reserve the right to change the above specifications.

Gratifiche E. GASPARI - Cadriano di G. (BO) - 04-2015